

NOTES:
UNLESS SPECIFIED IN THE DRAWING,
ALL PRODUCTS DISPLAYED IN THIS
DRAWING OTHER THAN THE CASE
ITSELF IS NOT PART OF OUR PRODUCT
OFFERING.

PRODUCT FEATURES

CONSTRUCTION

- 12MM BIRCH VENEER PLYWOOD WITH HPL EXTERIOR FACE AND PVC INTERIOR FACE
- 12X ERGONOMICALLY PLACED HANDLES FOR LIFTING AND TRANSPORTING
- LARGE LATCHES
- EVA38B FOAM PROTECTION
- 18MM PAIR CASTOR BOARD
- 4X 100MM CASTORS 2X BRAKED

FEATURES

- DEDICATED SPACE FOR 4X KOGAN KAQL55X98GSVA
- EASY TO USE LIFT-OFF-LID DESIGN
- TRUCK PACK FRIENDLY DIMENSIONS

KOGAN KAQL55XQ98GSVA

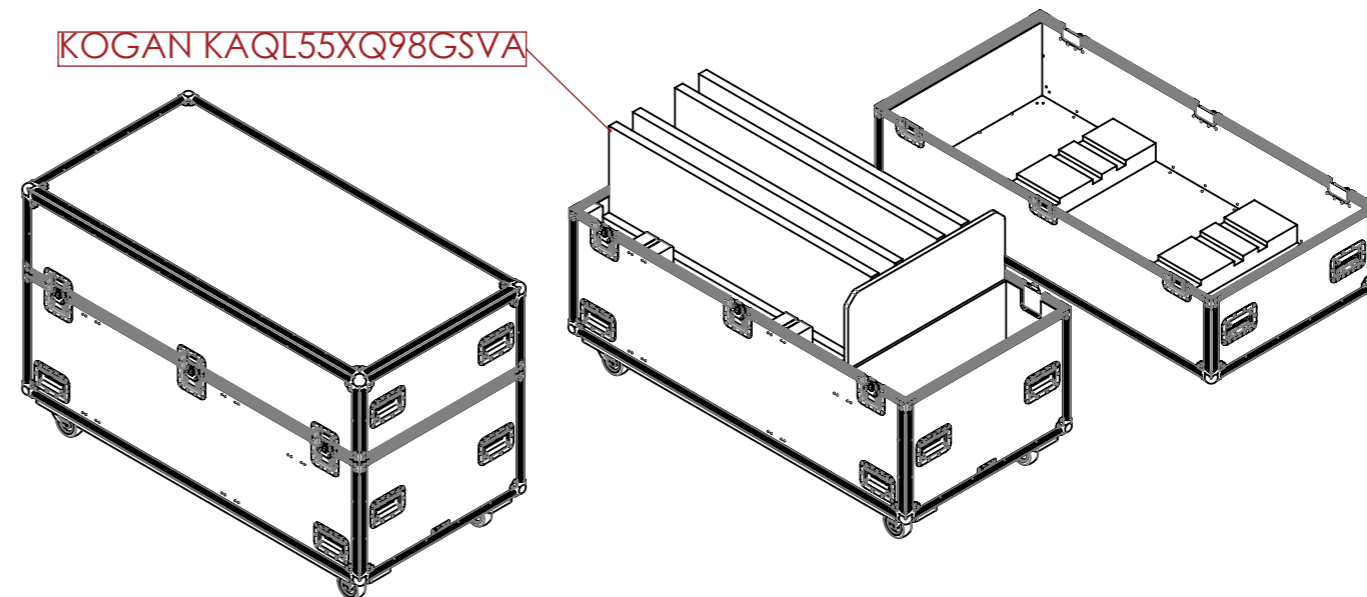

ESTIMATED WEIGHT (CASE ONLY):

92.4 KG

ITEM CODE:

TV-55Q-KGN-Q98GSVA

DRAWN BY:

HA

CHECKED BY:

AS

SCALE:

NTS



MAIL : sales@armorcases.com.au
WEB : www.armorcases.com.au