

SECTION A-A
SCALE 1 : 10

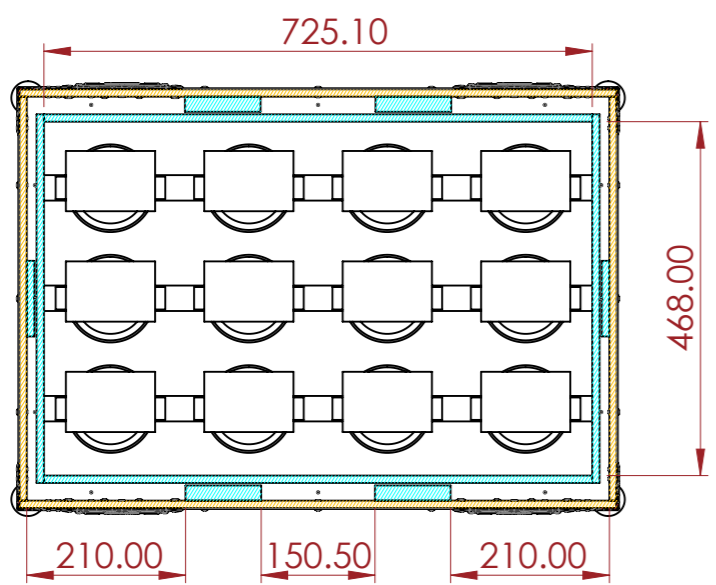

SECTION B-B
SCALE 1 : 10

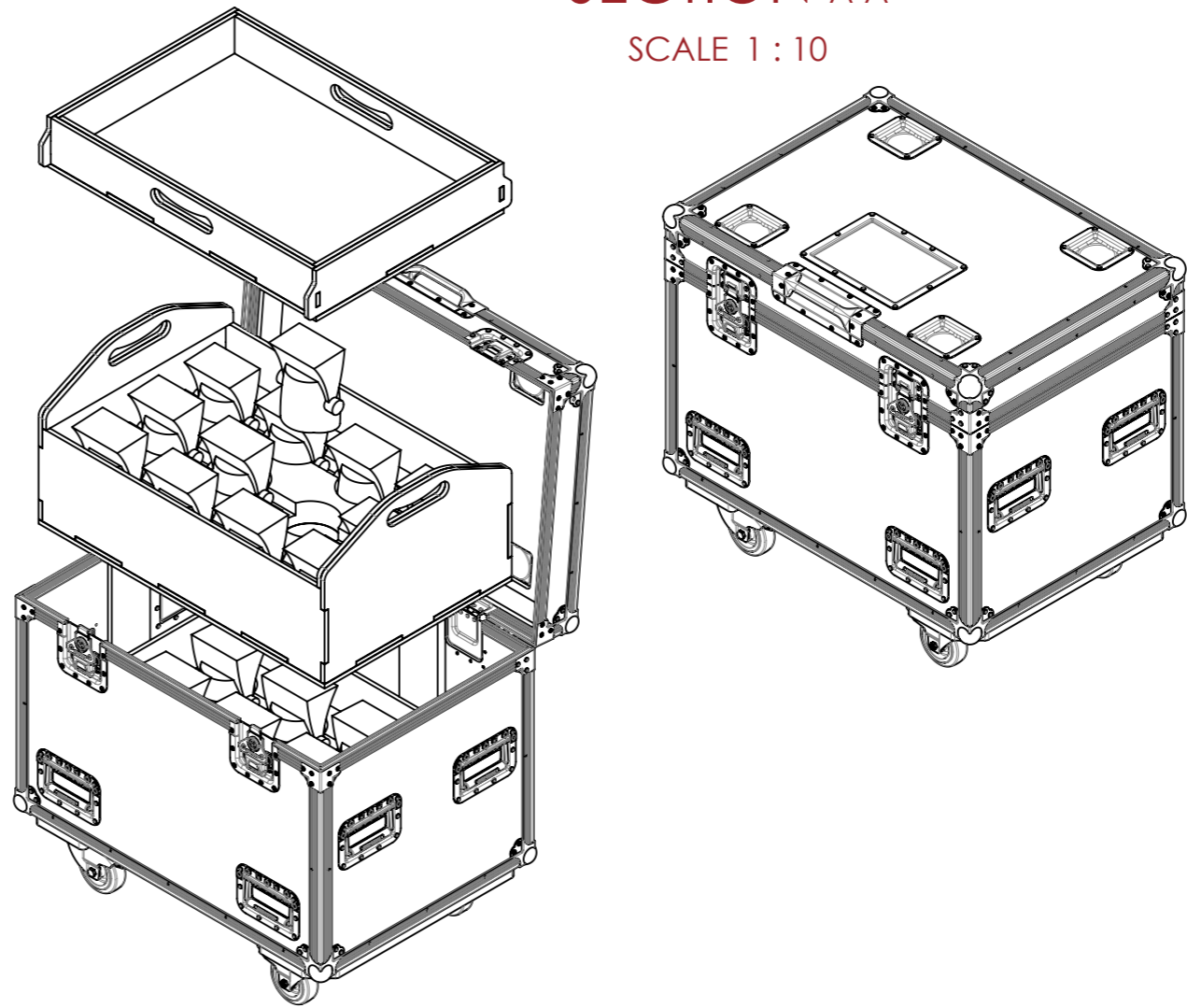

NOTES:
Your Notes Here

CUSTOMER:
Lachlan Robert

DUE DATE:

QUANTITY:
2

PANEL FINISH:

HARDWARE:

DRAWING:
LXPAR-EL-P1x24

DRAWN BY: HA
CHECKED BY: AS

SCALE: 1:10
REVISION: 1



ADD : 45/7-9 Percy St, Auburn,
NSW 2144, Australia
PH : 02 9188 6801
MAIL : sales@armorcases.com.au
WEB : www.armorcases.com.au