

SECTION A-A
SCALE 1 : 8

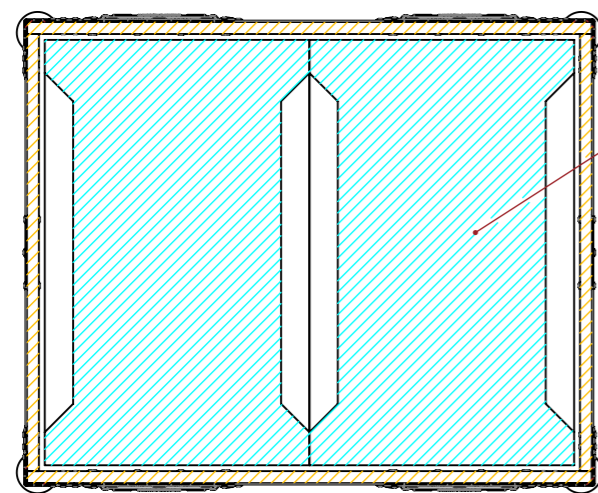

SECTION B-B
SCALE 1 : 8

LIGHT FOAM SHELL IS NOT INCLUDED WITH THIS PRODUCT

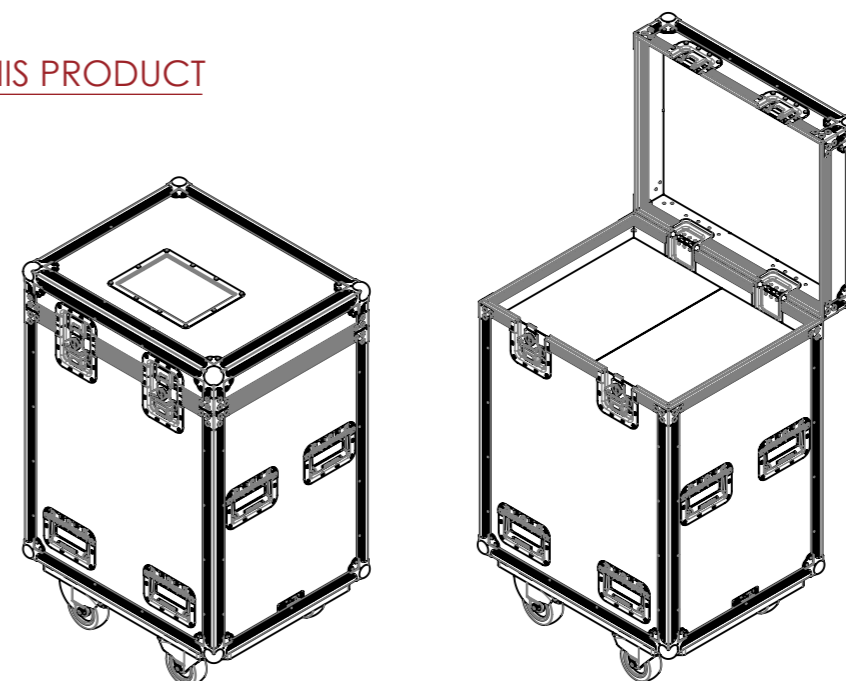

NOTES:

REV	DESCRIPTION	DATE
0	ORIGINAL ISSUE	10/31/2022

ESTIMATED WEIGHT (CASE ONLY):

34.74 KG

QUANTITY:

1

ITEM CODE:

LXMH-ARYTON-MISTRA

DRAWN BY:

KI

CHECKED BY:

AS

SCALE:

NTS



MAIL : sales@armorcases.com.au
 WEB : www.armorcases.com.au