

EVA FOAM

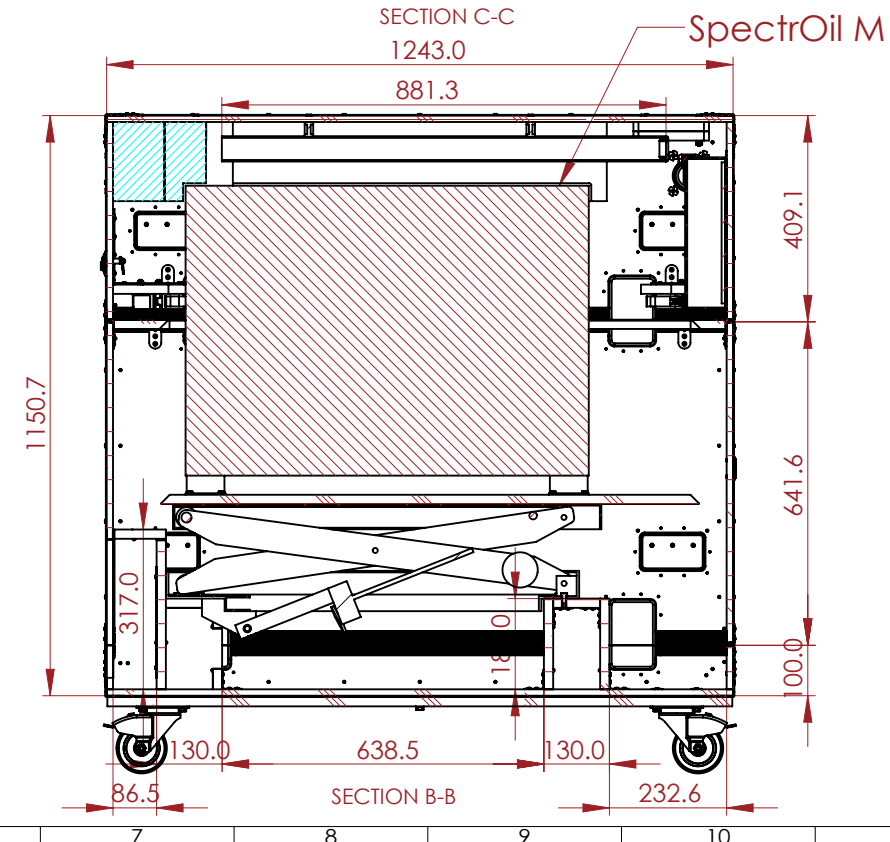

Spectroil M

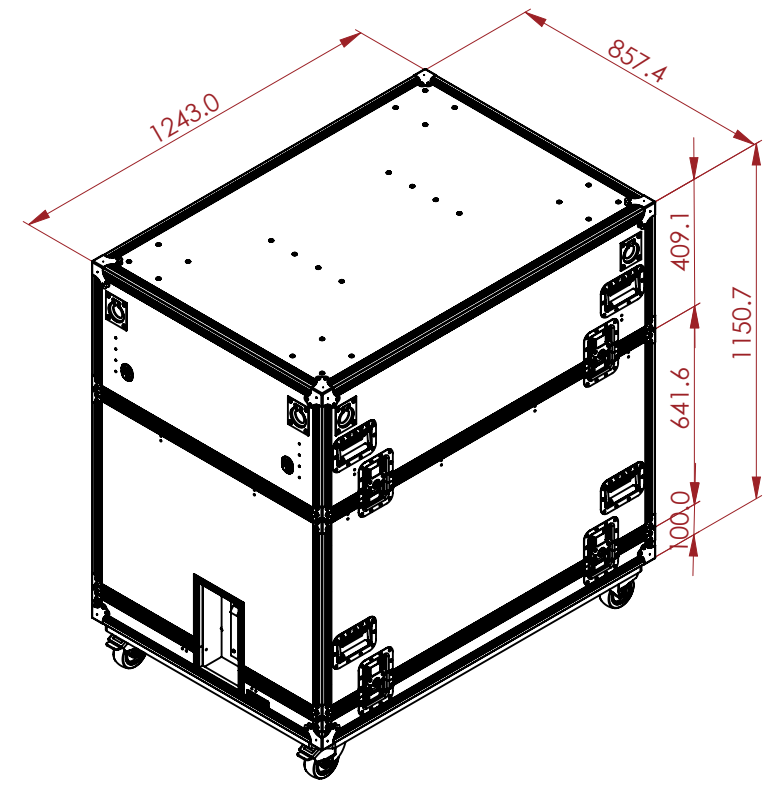
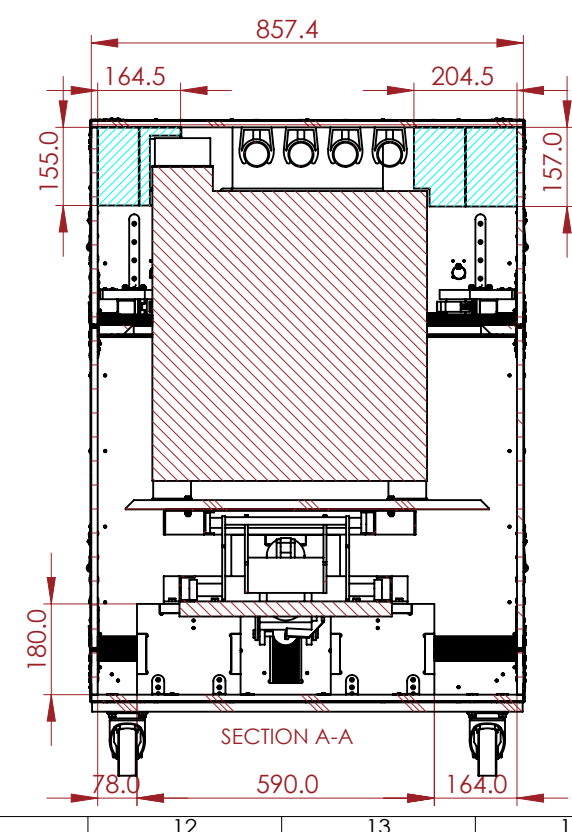

NOTES:

REV	DESCRIPTION	DATE
0	ORIGINAL ISSUE	11/06/2023
1	REMOVE HANDLES, MOUNTING HOLES ADJUSTMENTS, ADDITIONAL FOAM SUPPORT, TABLE LEGS GUIDE, ENCLOSED BOX	11/07/2023

ESTIMATED WEIGHT (CASE ONLY):
125.80 KG

QUANTITY:
2

ITEM CODE:
LIFT-CREA-SPECTROIL

DRAWN BY: RP
CHECKED BY: AS

SCALE:
NTS



ADD : 45/7-9 Percy St, Auburn,
NSW 2144, Australia
PH : 02 9188 6801
MAIL : sales@armorcases.com.au
WEB : www.armorcases.com.au