

SECTION A-A
SCALE 1 : 5

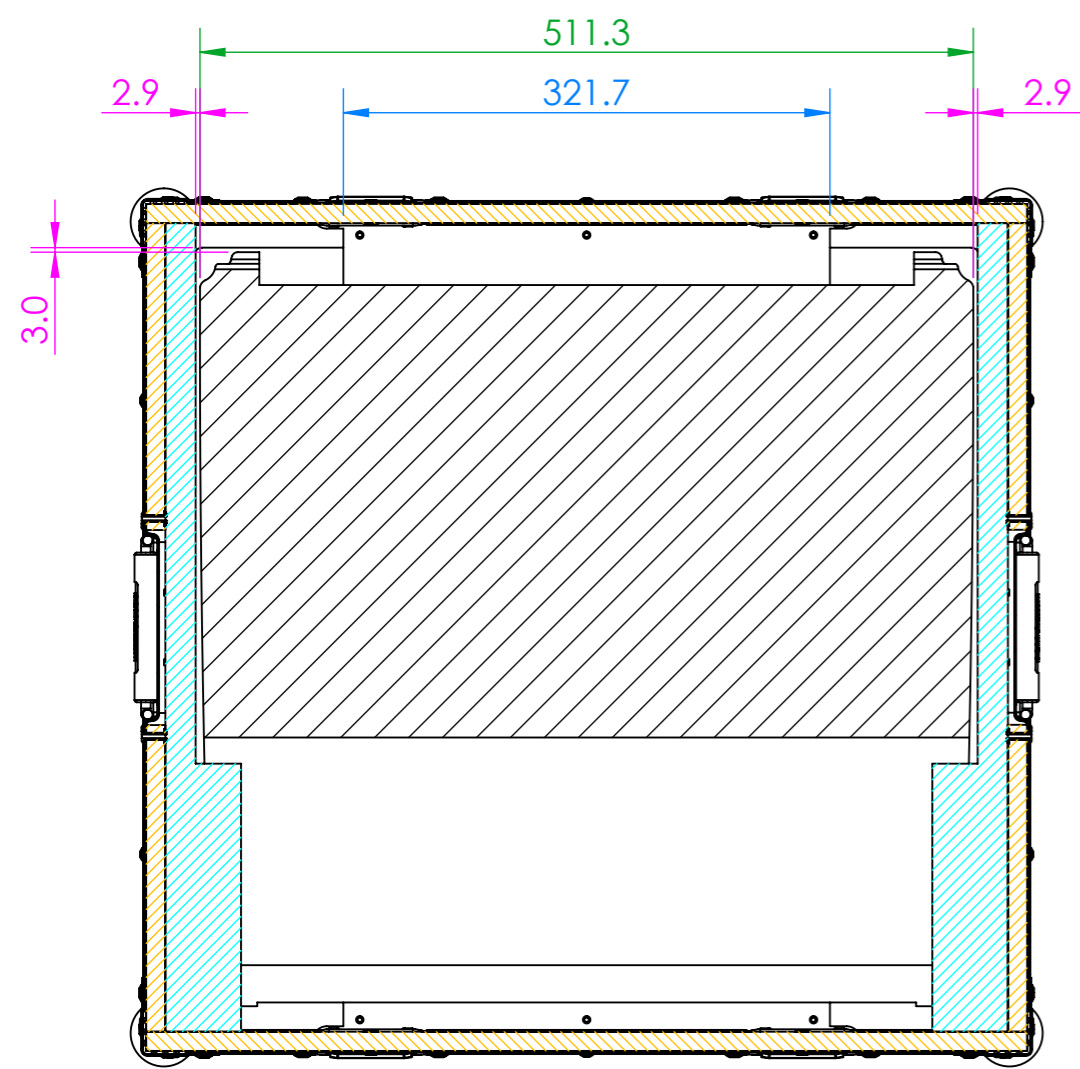

SECTION B-B
SCALE 1 : 5

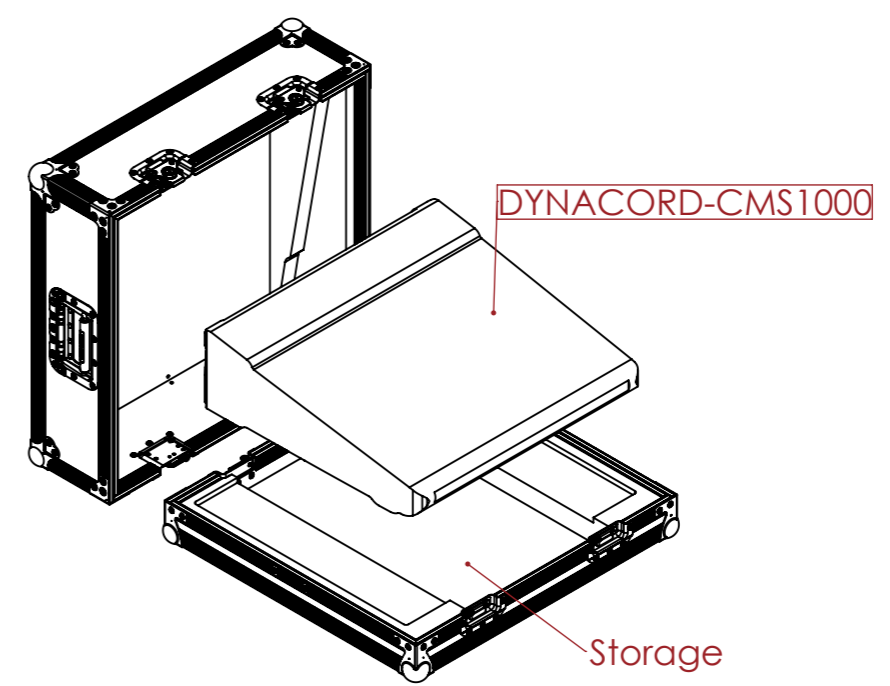
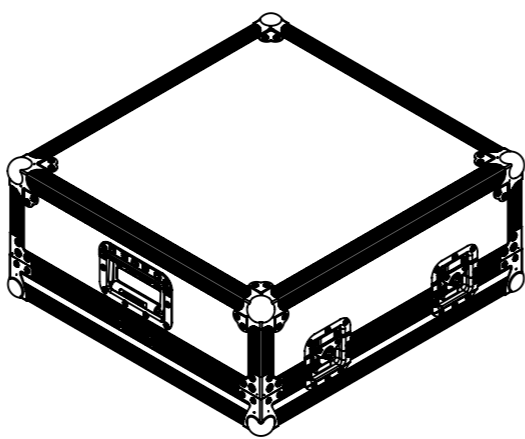

NOTES:
UNLESS SPECIFIED IN THE DRAWING,
ALL PRODUCTS DISPLAYED IN THIS
DRAWING OTHER THAN THE CASE
ITSELF IS NOT PART OF OUR PRODUCT
OFFERING.

- CARPET
- EVA FOAM
- PLYWOOD
- EXTERNAL DIMENSIONS
- INTERNAL DIMENSIONS
- TOLERANCES
- EQUIPMENT DIMENSIONS
- EPE 25 FOAM

REV	DESCRIPTION	DATE
0	ORIGINAL ISSUE	10/31/2022

ESTIMATED WEIGHT (CASE ONLY):
14.76 KG

ITEM CODE:
MIXR-DYNA-CMS1000

DRAWN BY: **HA** CHECKED BY: **AS**

SCALE:
NTS



MAIL : sales@armorcases.com.au
WEB : www.armorcases.com.au