

SECTION A-A

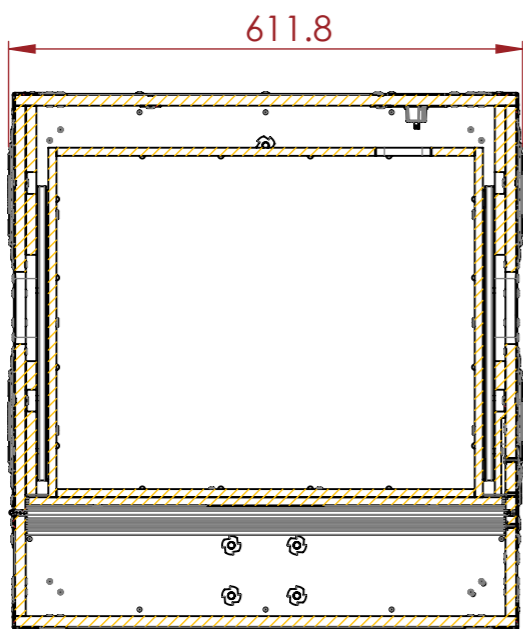

SECTION B-B

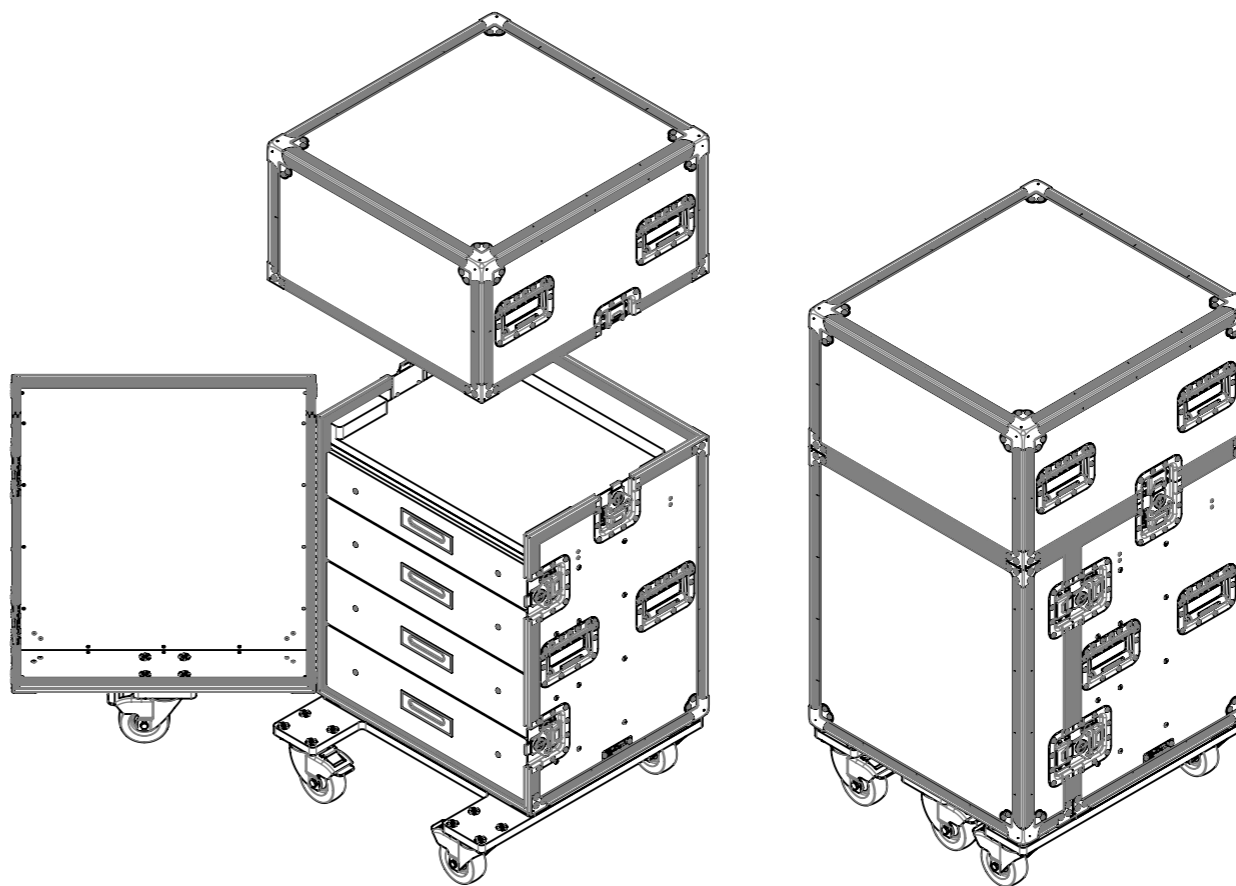

NOTES:
UNLESS SPECIFIED IN THE DRAWING,
ALL PRODUCTS DISPLAYED IN THIS
DRAWING OTHER THAN THE CASE
ITSELF IS NOT PART OF OUR PRODUCT
OFFERING.
TEST FIT ACTUAL ITEM BEFORE
FINISHING CASE BUILDING (REMOVE
THIS NOTE IF THERE WERE NO ACTUAL
ITEM TO FIT IN)

-  CARPET
-  EVA FOAM
-  PLYWOOD
-  EXTERNAL DIMENSIONS
-  INTERNAL DIMENSIONS
-  TOLERANCES
-  EQUIPMENT DIMENSIONS
-  EPE 25 FOAM

REV	DESCRIPTION	DATE
0	ORIGINAL ISSUE	10/31/2022

ESTIMATED WEIGHT (CASE ONLY):
74.25 KG

ITEM CODE:
UTL-DR6-EPSN-WF7840

DRAWN BY: **K.I** CHECKED BY: **AS**

SCALE:
NTS



MAIL : sales@armorcases.com.au
WEB : www.armorcases.com.au