

NOTES:
UNLESS SPECIFIED IN THE DRAWING,
ALL PRODUCTS DISPLAYED IN THIS
DRAWING OTHER THAN THE CASE
ITSELF IS NOT PART OF OUR PRODUCT
OFFERING.

PRODUCT FEATURES

CONSTRUCTION

- 9MM LAMINATED PLYWOOD PANEL
- EVA38 FOAM PROTECTION
- ARMOR HARDWARE
- 4 X 100MM CASTOR WHEELS
- 2 X MEDIUM LATCHES

FEATURES

- MAKE A KEYBOARD AND A STAND LIKE A NORMAL PIANO
- FOR YAMAHA P115 KEYBOARD OR LATER MODEL
- BALL CORNERS AND 30MM EXTRUSION EDGES
- EASY TO OPEN AND CLOSE LID DESIGN
- TWO BUILT IN LED LIGHT

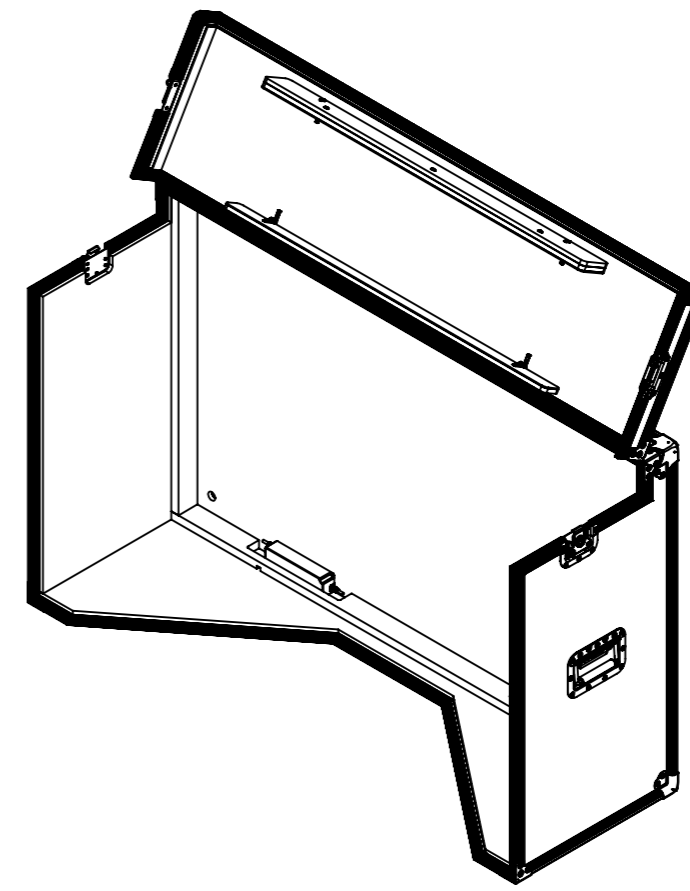
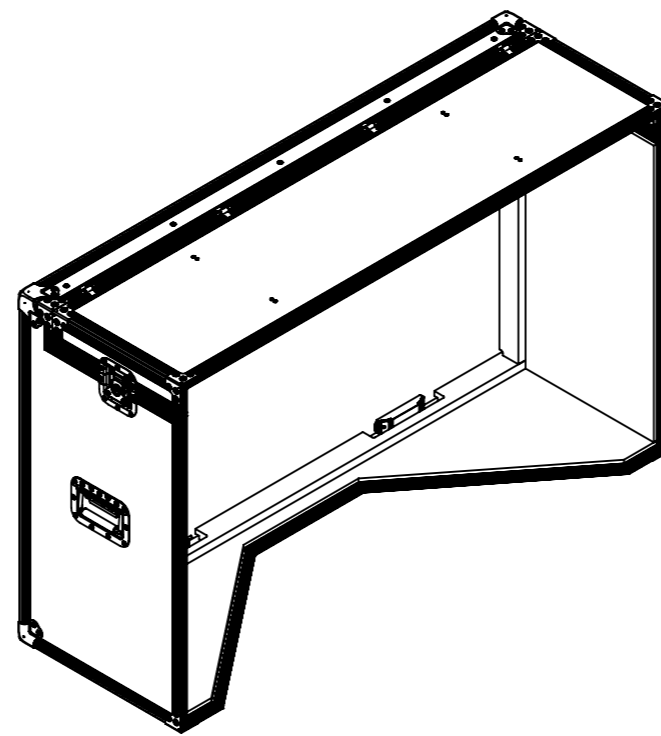

ESTIMATED WEIGHT (CASE ONLY):

26.55 KG

ITEM CODE:

FNTR-YMH-P115

DRAWN BY:

TJ

CHECKED BY:

AS

SCALE:

NTS



MAIL : sales@armorcases.com.au
WEB : www.armorcases.com.au