

NOTES:
UNLESS SPECIFIED IN THE DRAWING,
ALL PRODUCTS DISPLAYED IN THIS
DRAWING OTHER THAN THE CASE
ITSELF IS NOT PART OF OUR PRODUCT
OFFERING.

PRODUCT FEATURES

CONSTRUCTION

- 12MM LAMINATED PLYWOOD PANEL
- EVA38 FOAM PROTECTION
- PENNELCOM HARDWARE
- 2 X LARGE RECESSED HANDLES
- 4 X MEDIUM LATCHES

FEATURES

- STORAGE UNDER THE MIXER FOR ACCESSORIES
- BALL CORNER AND 30MM EXTRUSION EDGES
- EASY TO USE LIFT OFF LID DESIGN

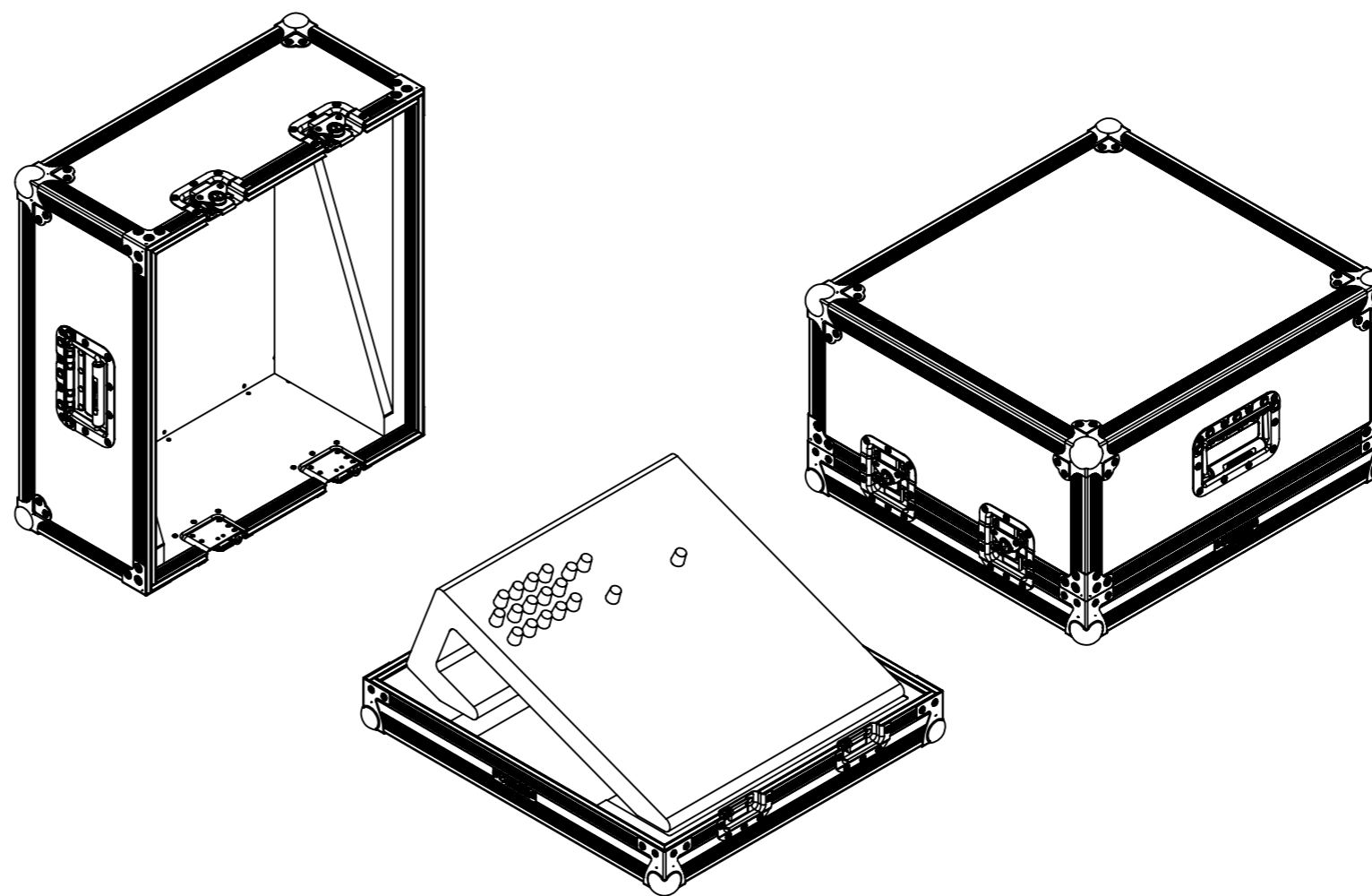

ESTIMATED WEIGHT (CASE ONLY):

14.93 KG

ITEM CODE:

MIXR-AH-QU16

DRAWN BY:

TJ

CHECKED BY:

AS

SCALE:

NTS



MAIL : sales@armorcases.com.au
WEB : www.armorcases.com.au