

NOTES:
UNLESS SPECIFIED IN THE DRAWING,
ALL PRODUCTS DISPLAYED IN THIS
DRAWING OTHER THAN THE CASE
ITSELF IS NOT PART OF OUR PRODUCT
OFFERING.

PRODUCT FEATURES

CONSTRUCTION

- 12MM LAMINATED PLYWOOD PANEL
- 18MM FULL CASTOR BOARD
- EVA38 FOAM PROTECTION
- PENNELCOM HARDWARE
- 14 X SLIM RECESSED HANDLES
- 4 X LARGE LATCHES
- 4 X 75MM CASTOR WHEELS

FEATURES

- STORAGE FOR ACCESSORIES UNDER THE MIXER
- DOG BOX DESIGN - EASY ACCESS TO CABLES
- BALL CORNER AND 30MM EXTRUSION EDGES
- EASY TO USE LIFT OFF LID DESIGN
- ENGRAVING LOGO AT TOP

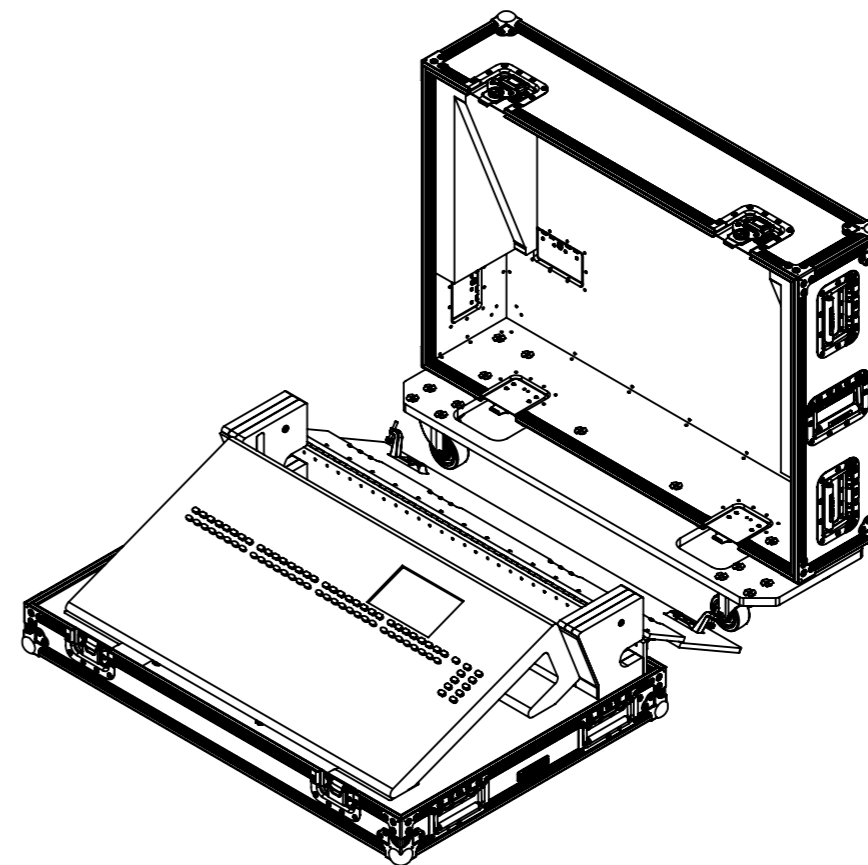
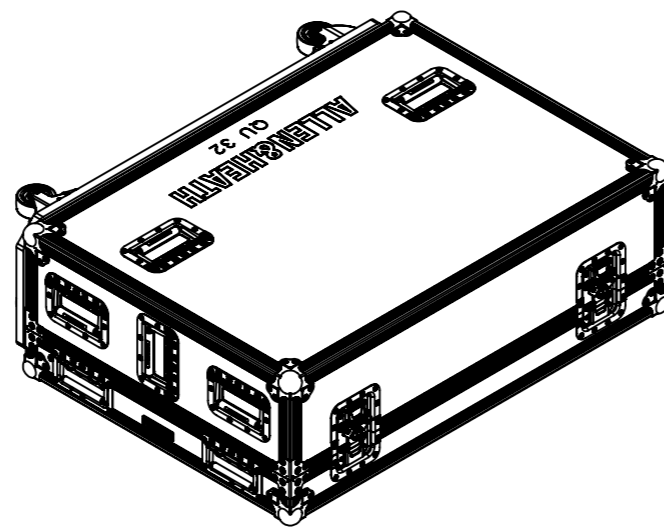

ESTIMATED WEIGHT (CASE ONLY):

44.5 KG

ITEM CODE:

MIXR-AH-QU32

DRAWN BY:

TJ

CHECKED BY:

AS

SCALE:

NTS



MAIL : sales@armorcases.com.au
WEB : www.armorcases.com.au