

**PRODUCT FEATURES**

**CONSTRUCTION:**

- 12MM HIGH QUALITY PLYWOOD PANEL
- ALUMINIUM EXTRUSIONS
- STEEL BALL CORNERS

**INSTALLED EQUIPMENT:**

- 2X ERGONOMIALLY PLACED HANDLES FOR LIFTING AND TRANSPORTING
- MEDIUM LATCHES AND LARGE HANDLES
- EVA38B FOAM PROTECTION

**FEATURES:**

- DEDICATED SPACE FOR ALLEN AND HEATH-QUPAC
- GENERAL PURPOSE STORAGE FOR ACCESSORIES
- TRUCK FRIENDLY CASE

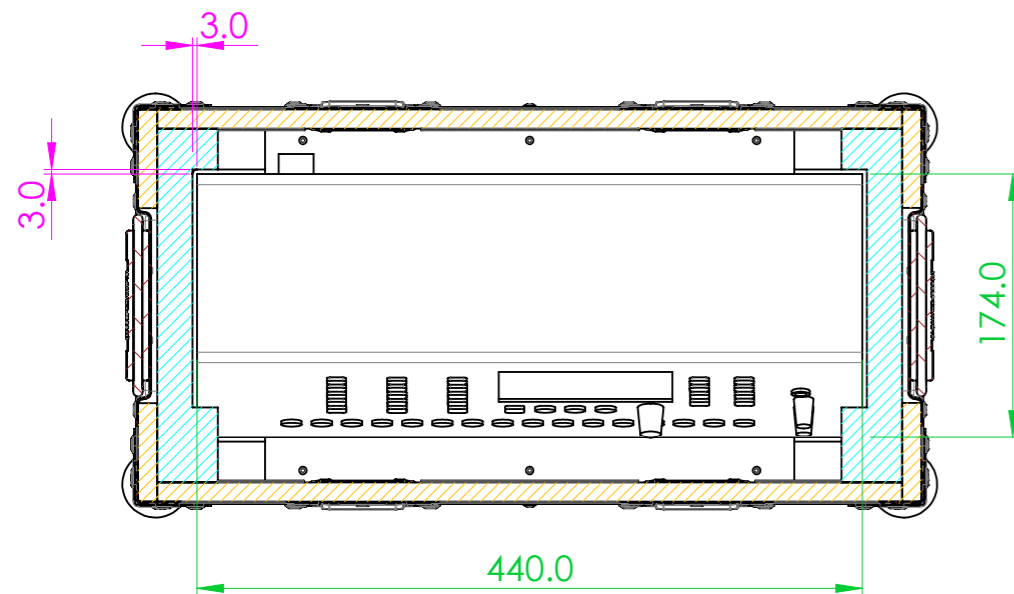

SECTION B-B  
SCALE 1 : 5

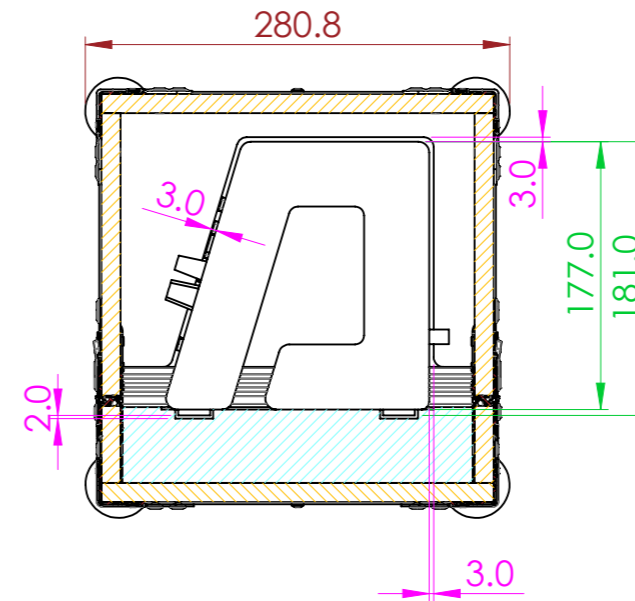

SECTION A-A  
SCALE 1 : 5

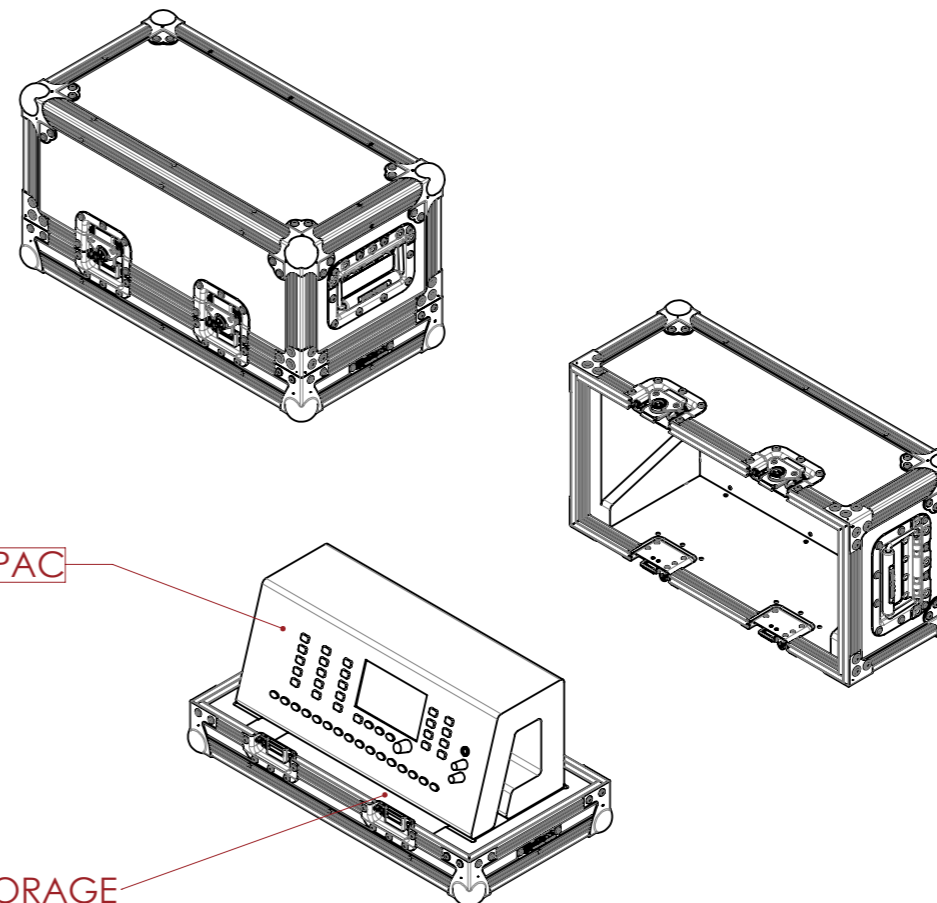

ALLEN AND HEATH-QUPAC

STORAGE

NOTES:  
UNLESS SPECIFIED IN THE DRAWING,  
ALL PRODUCTS DISPLAYED IN THIS  
DRAWING OTHER THAN THE CASE  
ITSELF IS NOT PART OF OUR PRODUCT  
OFFERING.

- CARPET
- EVA FOAM
- PLYWOOD
- EXTERNAL DIMENSIONS
- INTERNAL DIMENSIONS
- TOLERANCES
- EQUIPMENT DIMENSIONS
- EPE 25 FOAM

REV	DESCRIPTION	DATE
0	ORIGINAL ISSUE	10/31/2022

ESTIMATED WEIGHT (CASE ONLY):  
9.05 KG

ITEM CODE:  
MIXR-AH-QUPAC

DRAWN BY: HA                      CHECKED BY: AS

SCALE:  
NTS



MAIL : sales@armorcases.com.au  
WEB : www.armorcases.com.au