

PRODUCT FEATURES

CONSTRUCTION

- 12MM BIRCH VENEER PLYWOOD WITH HPL EXTERIOR FACE AND PVC INTERIOR FACE
- PENN ELCOM HARDWARE

FEATURES

- LIFT-OFF LID TO STORE CHAMSYS MQ60 AUDIO MIXER
- STORAGE SPACE UNDER THE MIXER FOR ACCESSORIES
- ENGRAVING & LABEL DISH FOR BETTER IDENTIFICATION

NOTES:
UNLESS SPECIFIED IN THE DRAWING,
ALL PRODUCTS DISPLAYED IN THIS
DRAWING OTHER THAN THE CASE
ITSELF IS NOT PART OF OUR PRODUCT
OFFERING.

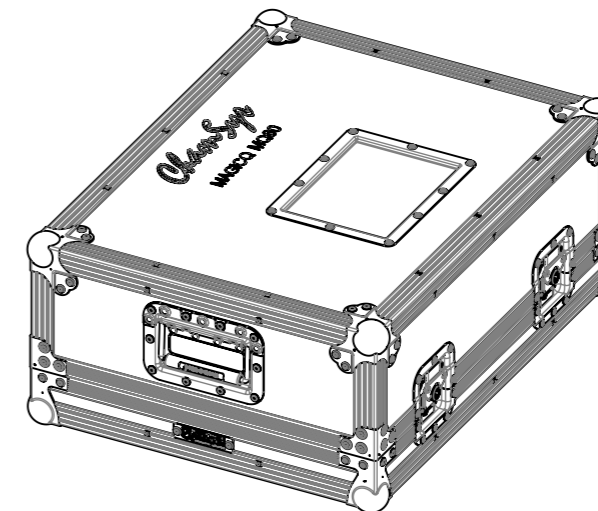
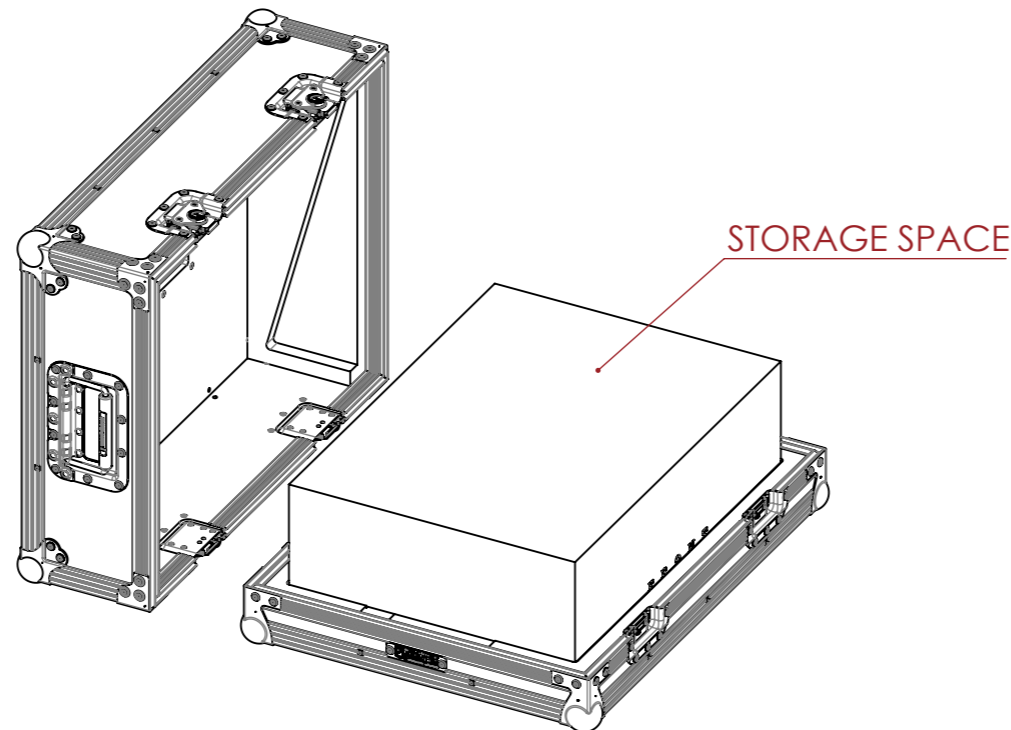
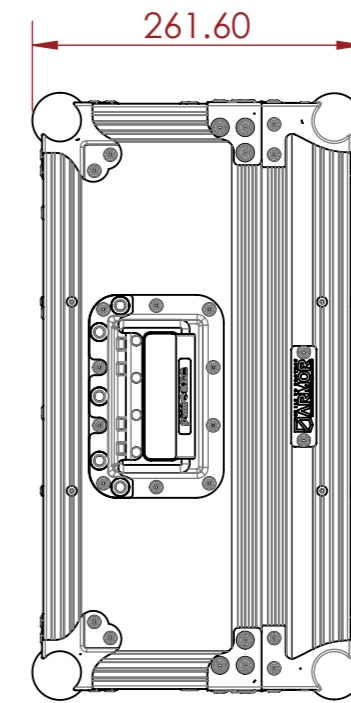
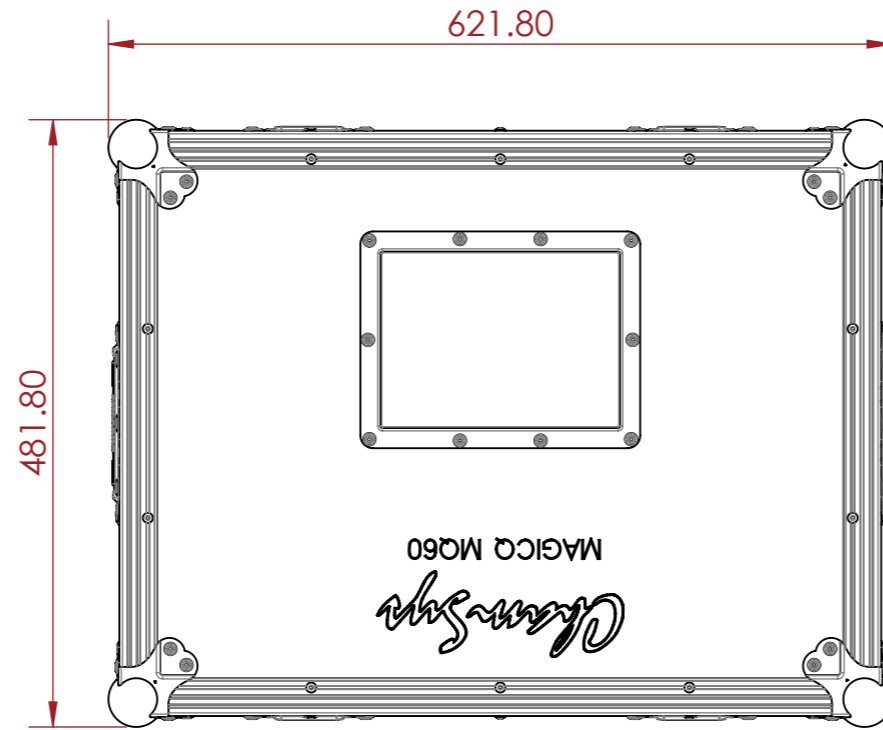

ESTIMATED WEIGHT (CASE ONLY):

8.16 KG

ITEM CODE:

MIXR-CHS-MQ60

DRAWN BY:

KI

CHECKED BY:

AS

SCALE:

NTS



MAIL : sales@armorcases.com.au
WEB : www.armorcases.com.au

CUSTOMER NAME:

QTY IN THIS BATCH:



BUILT BY:

DUE DATE:

MAIL : sales@armorcases.com.au
WEB : www.armorcases.com.au

THESE NOTES SHOULD BE REMOVED BEFORE MAKING A DRAWING:

1. THIS SHEET IS MEANT TO BE USED FOR THE SOLE PURPOSE OF COMMUNICATING TECHNICAL INFORMATION TO THE WORKSHOP.
2. THE CASE DRAWING SHOULD INCLUDE THE FOLLOWING DIMENSIONS:
 - A) EXTERNAL DIMENSIONS INCLUDING HARDWARE. THE LAYER NAMED "DIMENSIONS" (RED) WILL BE USED FOR THIS.
 - B) EXTERNAL PANEL TO PANEL DIMENSIONS. LAYER "CUTOUT" (BLUE) SHOULD BE USED FOR THESE DIMENSIONS.
3. EXTRUSION LAYOUTS SHOULD BE DISPLAYED WITH DIMENSIONS SHOWING THE LENGTH OF EXTRUSIONS REQUIRED & A BALLOON SHOWING THE EXTRUSION TYPE.
4. WHEN PROVIDING DIMENSIONS FOR HYBRID EXTRUSIONS THAT HAVE BENDS ON THEM, START DIMENSIONING FROM THE LEFT HAND SIDE.
5. BREAKS BETWEEN EXTRUSIONS CAUSED BY THE PRESENCE OF LATCHES OR ANY OTHER HARDWARE DO NOT NEED TO BE DIMENSIONED.
6. EXTRUSIONS HAVING RIVETS, SHOULD INCLUDE THE LOCATION OF THE FIRST RIVET STARTING FROM THE NEAREST END OF THAT EXTRUSION

INITIALS

DATE

HOURS

ROUTING INFORMATION



MAIL : sales@armorcases.com.au
WEB : www.armorcases.com.au

A
—
B
—
C
—
D
—
E
—
F
—
G
—
H

1 | 2 | 3 | 4 | 5 | 6 | 7 | 8 | 9 | 10 | 11 | 12 | 13 | 14 | 15 | 16

1 | 2 | 3 | 4 | 5 | 6 | 7 | 8 | 9 | 10 | 11 | 12 | 13 | 14 | 15 | 16

NOTES:

UNLESS SPECIFIED IN THE DRAWING, ALL PRODUCTS DISPLAYED IN THIS DRAWING OTHER THAN THE CASE ITSELF IS NOT PART OF OUR PRODUCT OFFERING.

TEST FIT ACTUAL ITEM BEFORE FINISHING CASE BUILDING (REMOVE THIS NOTE IF THERE WERE NO ACTUAL ITEM TO FIT IN)

-  CARPET
-  EVA FOAM
-  PLYWOOD
-  EXTERNAL DIMENSIONS
-  INTERNAL DIMENSIONS
-  TOLERANCES
-  EQUIPMENT DIMENSIONS
-  EPE 25 FOAM

REV	DESCRIPTION	DATE
0	ORIGINAL ISSUE	10/31/2022

ESTIMATED WEIGHT (CASE ONLY):
8.16 KG

ITEM CODE:
MIXR-CHS-MQ60

DRAWN BY: **KI** CHECKED BY: **AS**

SCALE:
NTS



MAIL : sales@armorcases.com.au
WEB : www.armorcases.com.au