

NOTES:
UNLESS SPECIFIED IN THE DRAWING,
ALL PRODUCTS DISPLAYED IN THIS
DRAWING OTHER THAN THE CASE
ITSELF IS NOT PART OF OUR PRODUCT
OFFERING.

PRODUCT FEATURES

CONSTRUCTION

- 9MM HIGH QUALITY PLYWOOD PANEL
- PENN ELCOM HARDWARE

INSTALLED EQUIPMENT

- 8X ERGONOMIALLY PLACED HANDLES FOR LIFTING AND TRANSPORTING
- LARGE LATCHES AND HANDLES
- EVA38B FOAM PROTECTION
- 100MM LARGE CASTORS

FEATURES

- DEDICATED SPACE FOR 2x QSC-LA108 SEPAKERS
- 4x STEEL CASTOR DISHES FOR STACKING
- MAKE AND MODEL ENGRAVING ON THE PANELS

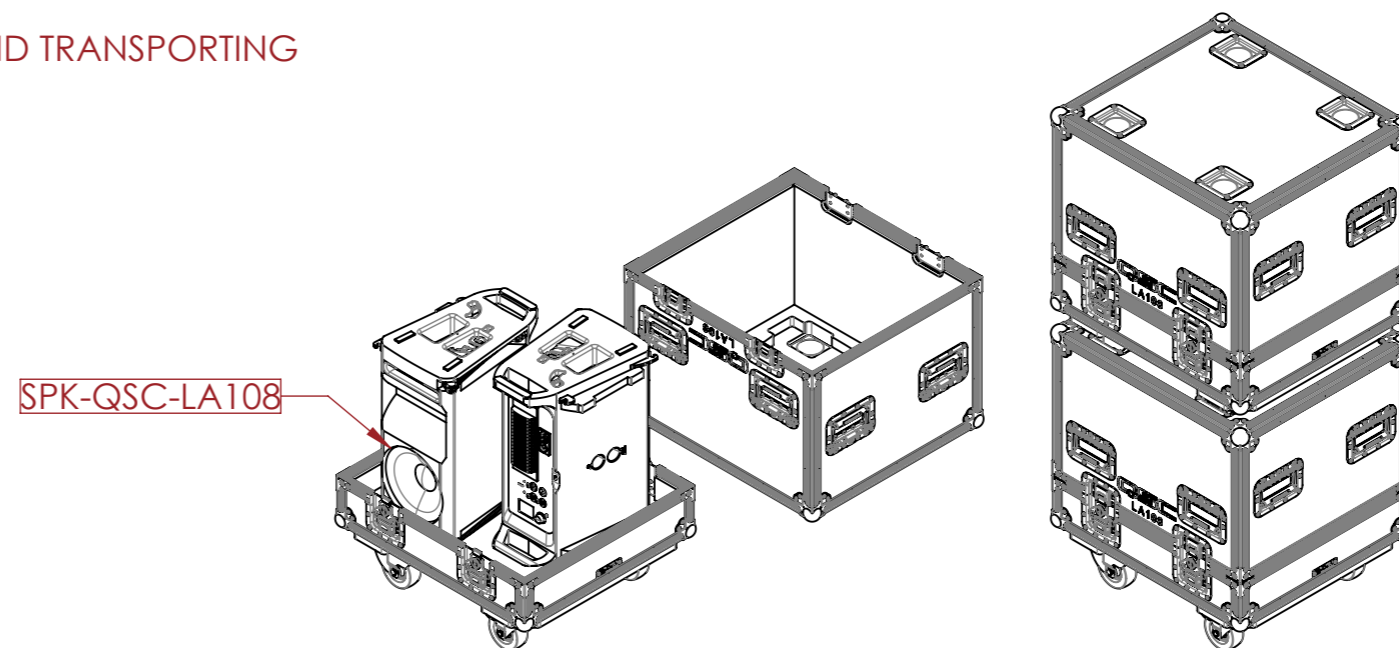

ESTIMATED WEIGHT (CASE ONLY):

29.53 KG

ITEM CODE:

SPK-QSC-LA108

DRAWN BY:

HA

CHECKED BY:

AS

SCALE:

NTS



MAIL : sales@armorcases.com.au
WEB : www.armorcases.com.au