

## PRODUCT FEATURES

### CONSTRUCTION

- 12MM BIRCH VENEER PLYWOOD WITH HPL EXTERIOR FACE AND PVC INTERIOR FACE
- ARMOR HARDWARE

### FEATURES

- TRUCK FRIENDLY DIMENSIONS
- 8 DRAWERS WITH RECESSED HANDLES
- 523MM X 471MM X 135MM INTERNAL DRAWER DIMENSIONS
- DRAWERS ARE CARPETS LINED ON THE BOTTOM

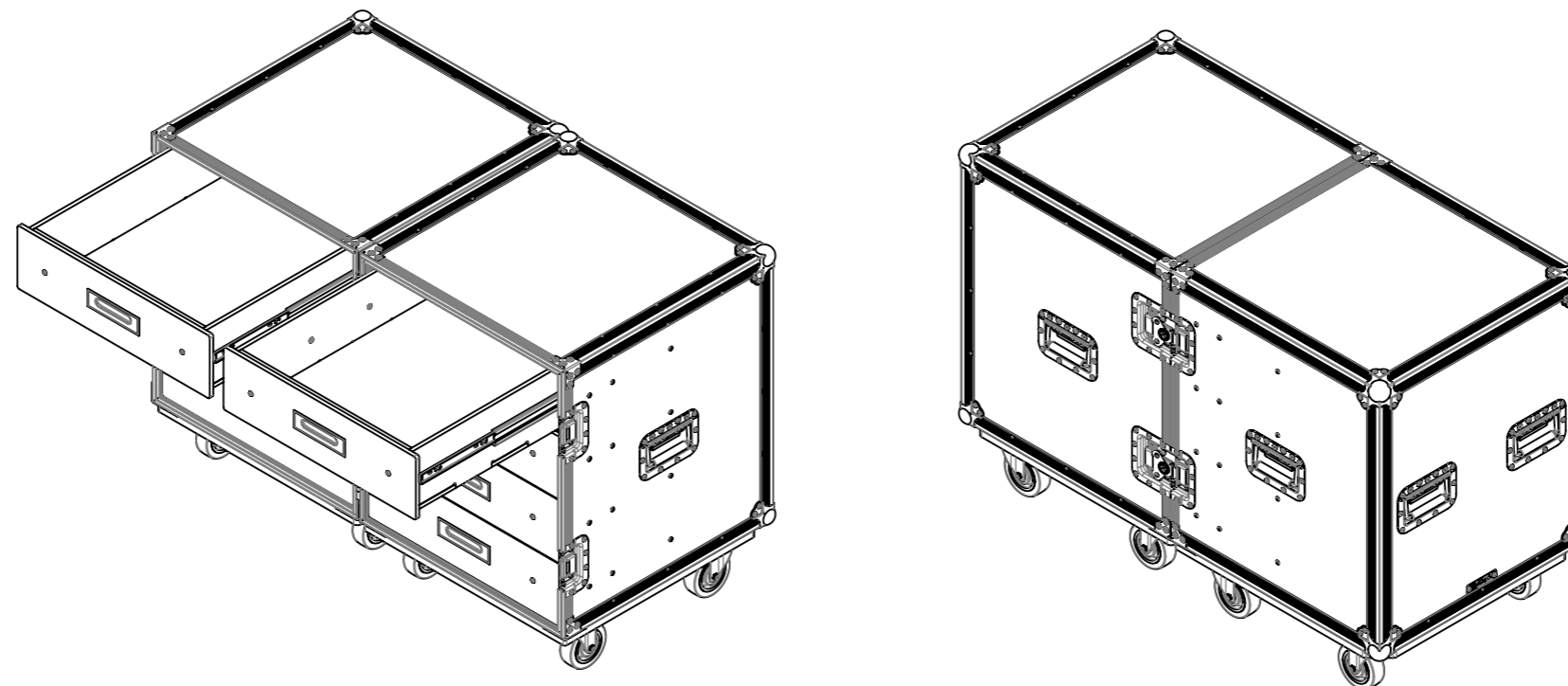
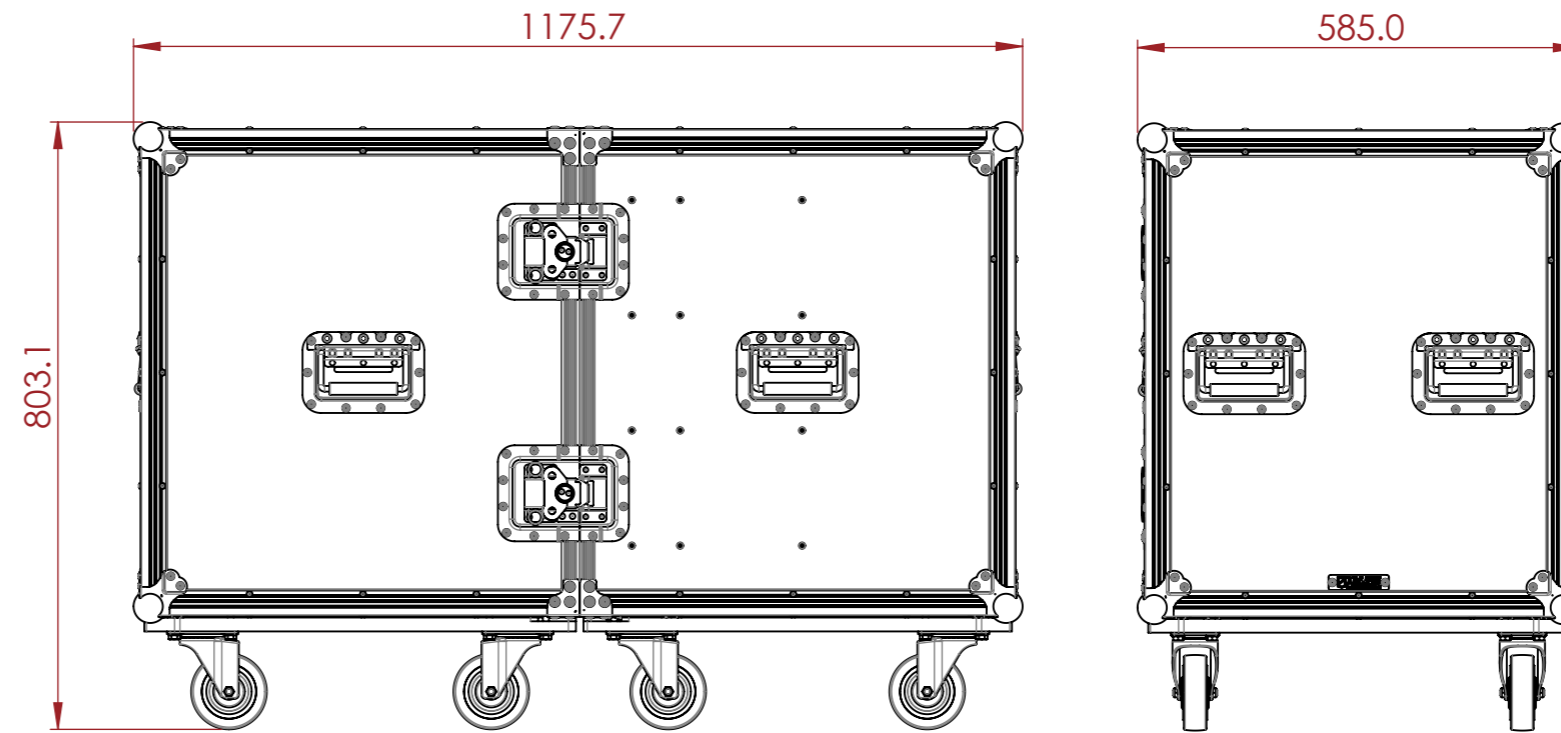

### NOTES:

UNLESS SPECIFIED IN THE DRAWING, ALL PRODUCTS DISPLAYED IN THIS DRAWING OTHER THAN THE CASE ITSELF IS NOT PART OF OUR PRODUCT OFFERING.

ESTIMATED WEIGHT (CASE ONLY):

104.41 KG

ITEM CODE:

UTL-DR8-CS

DRAWN BY:

K.I

CHECKED BY:

AS

SCALE:

NTS



MAIL : [sales@armorcases.com.au](mailto:sales@armorcases.com.au)  
WEB : [www.armorcases.com.au](http://www.armorcases.com.au)