

PRODUCT FEATURES

CONSTRUCTION

- 12MM HIGH QUALITY PLYWOOD PANEL
- ALUMINIUM EXTRUSIONS
- PENN ELCOM HARDWARE
- EVA FOAM

FEATURES

- DEDICATED SPACE FOR THE MG30FX AND ADDITIONAL ACCESSORIES
- BRAKED CASTOR WHEELS
- EASY TO LIFT LID

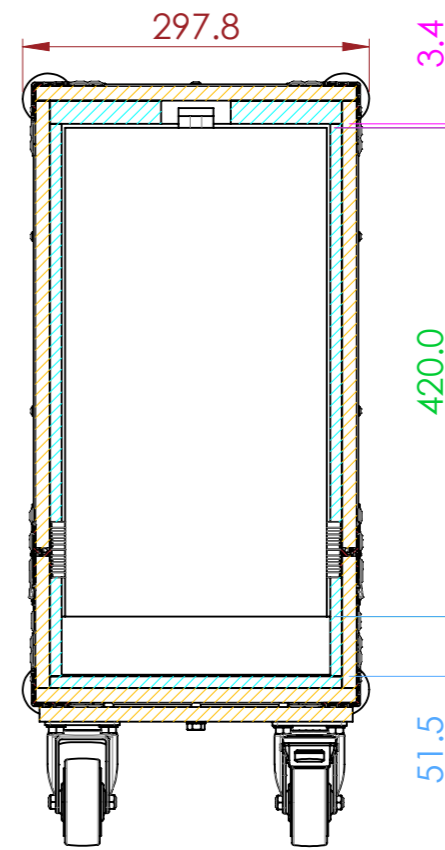

SECTION A-A

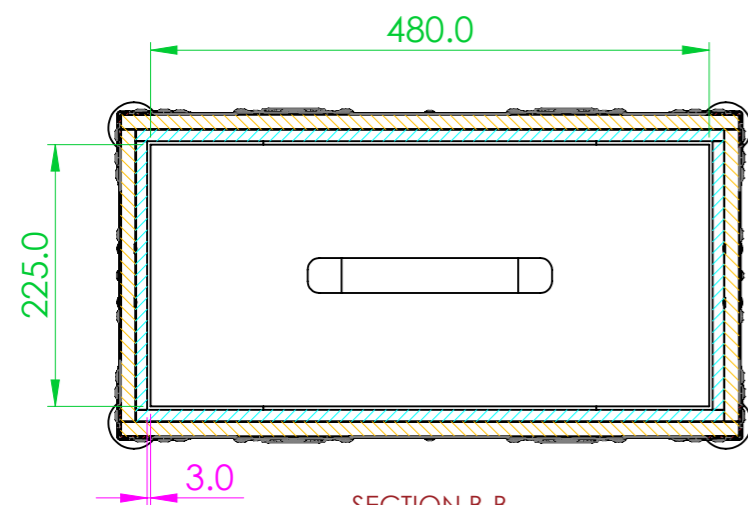

SECTION B-B

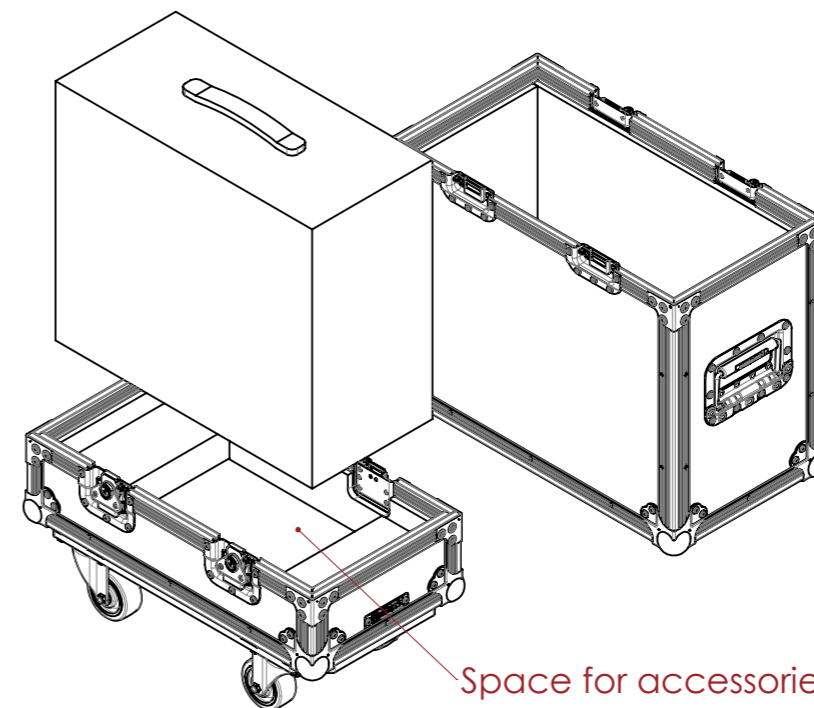
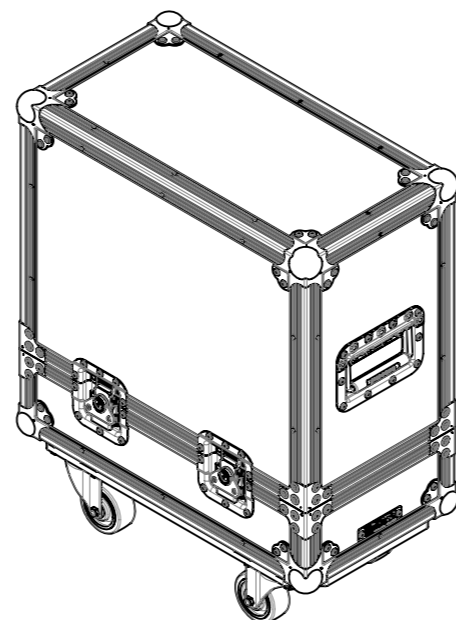

Space for accessories

NOTES:
UNLESS SPECIFIED IN THE DRAWING,
ALL PRODUCTS DISPLAYED IN THIS
DRAWING OTHER THAN THE CASE
ITSELF IS NOT PART OF OUR PRODUCT
OFFERING.

ESTIMATED WEIGHT (CASE ONLY):

18.4 KG

ITEM CODE:

AMP-MAS-MG30FX

DRAWN BY:

HA

CHECKED BY:

AS

SCALE:

NTS



MAIL : sales@armorcases.com.au
WEB : www.armorcases.com.au