

PRODUCT FEATURES

CONSTRUCTION

- 9MM BIRCH VENEER PLYWOOD WITH HPL EXTERIOR FACE AND PVC INTERIOR FACE
- PENN ELCOM HARDWARE

INSTALLED EQUIPMENT (INCLUDED)

- TWO MONITOR VESA ATTACHMENTS FOR 15IN MONITORS, 100 X 100 VESA MOUNTS
- 1RU 6-WAY PDU MOUNTED IN THE BACK
- LEDs STRIP LIGHTS

FEATURES

- 1X PULL OUT DRAWER FOR STORING ACCESSORIES
- 1X PULL OUT DRAWER FOR MOUSE AND KEYBOARD
- SPACE TO STORE GRANDMA2 ONPC COMMAND & FADER WING SIDE BY SIDE
- LABEL DISH FOR EASE OF RECOGNITION

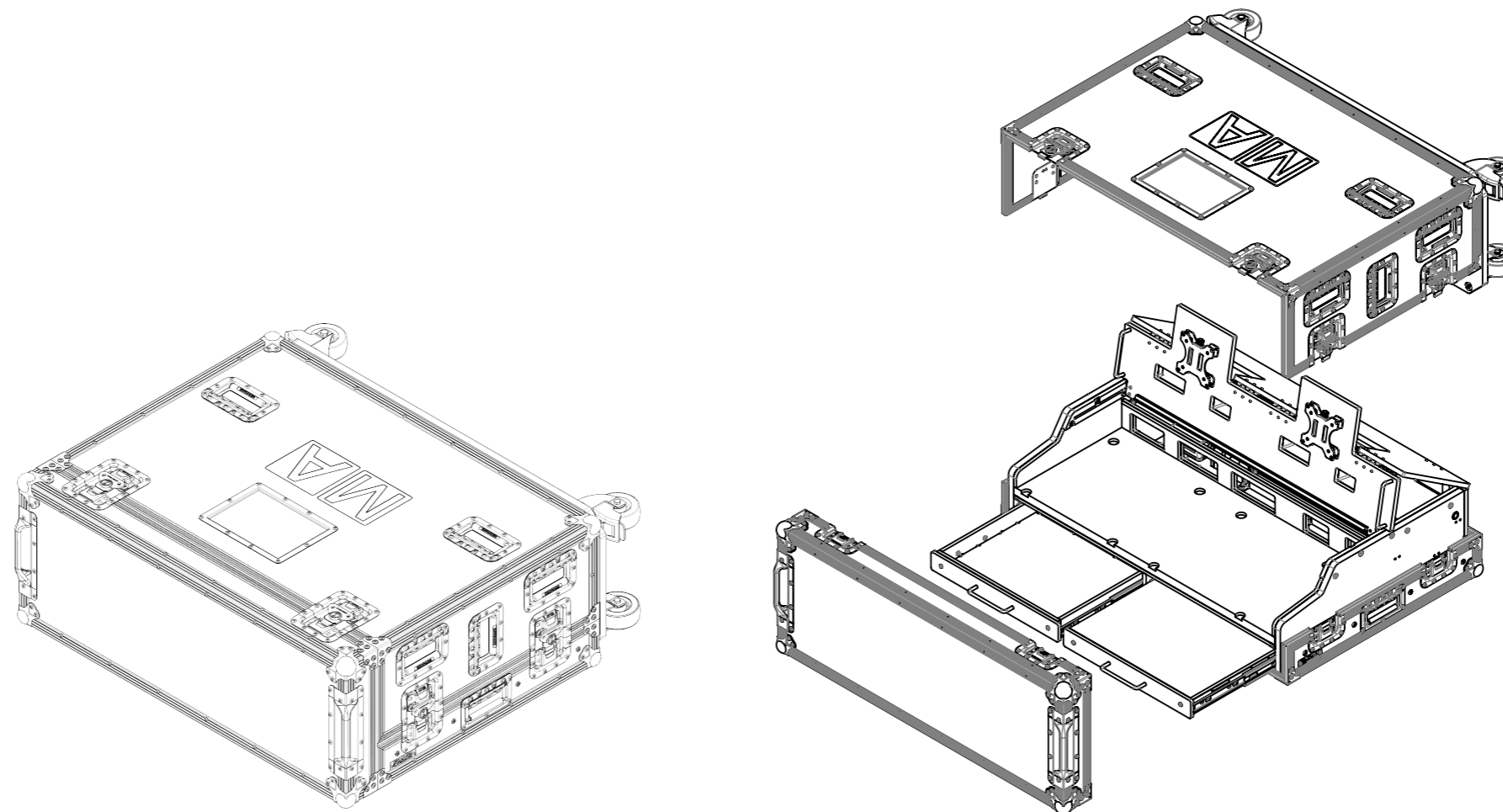
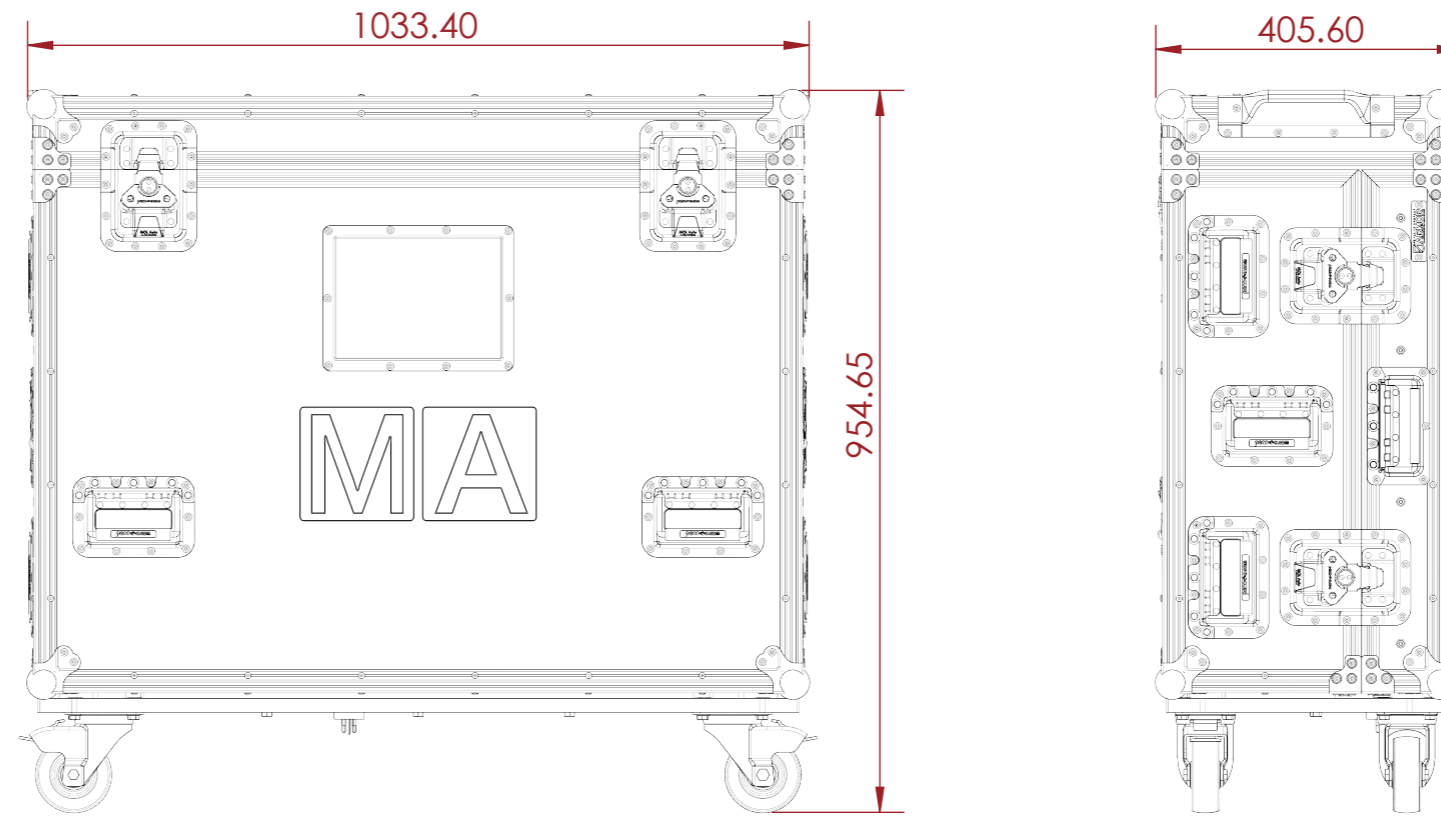

NOTES:

UNLESS SPECIFIED IN THE DRAWING, ALL PRODUCTS DISPLAYED IN THIS DRAWING OTHER THAN THE CASE ITSELF IS NOT PART OF OUR PRODUCT OFFERING.

ESTIMATED WEIGHT (CASE ONLY):

70.00 KG

ITEM CODE:

LXCTRL-MA2-CWF2-D15

DRAWN BY:

K.I

CHECKED BY:

AS

SCALE:

NTS



MAIL : sales@armorcases.com.au
WEB : www.armorcases.com.au