

GAS STRUT (GS-360-135-16C)
 EXTENDED LENGTH : 360mm
 STROKE LENGTH : 135mm
 ENDPLATE : TYPE C
 CAPACITY : 16kg

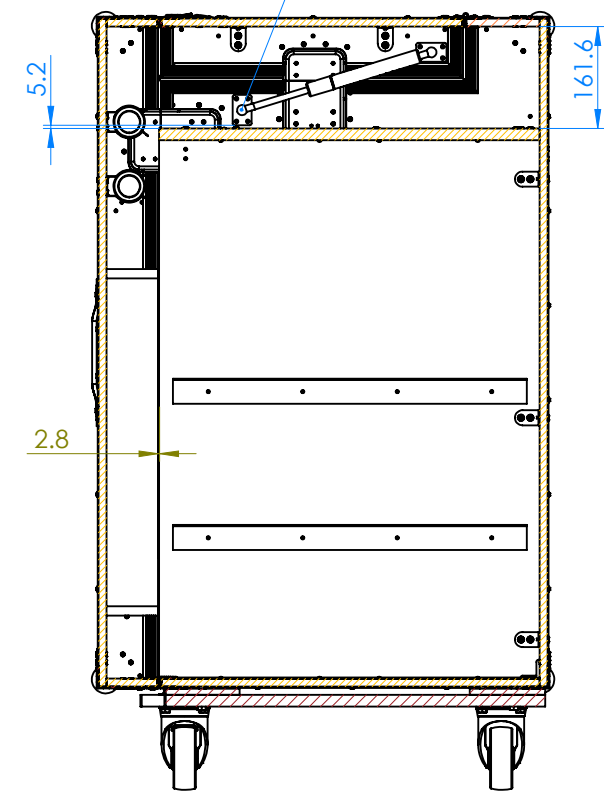

SECTION A-A

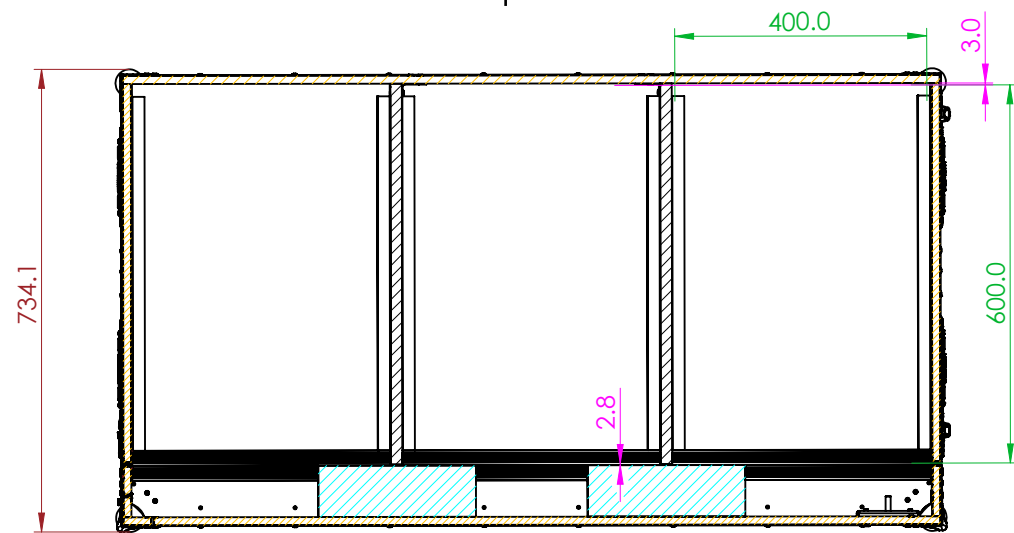

SECTION C-C

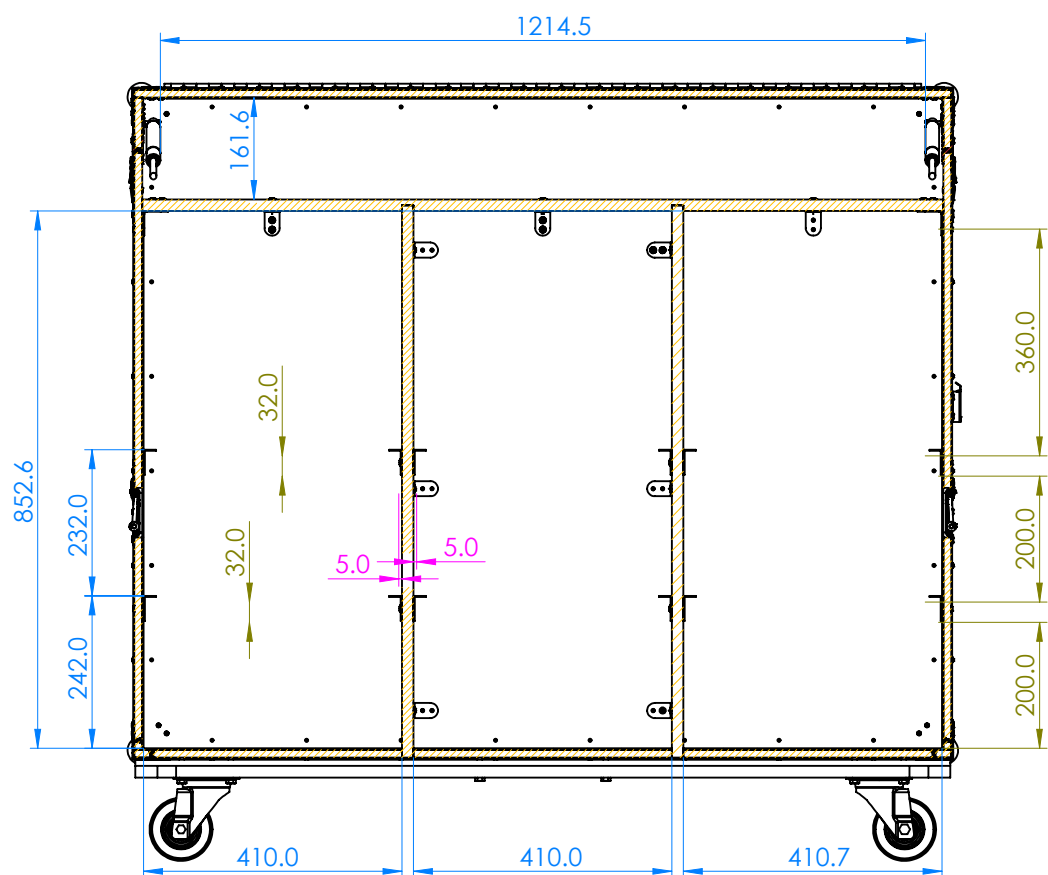

SECTION B-B

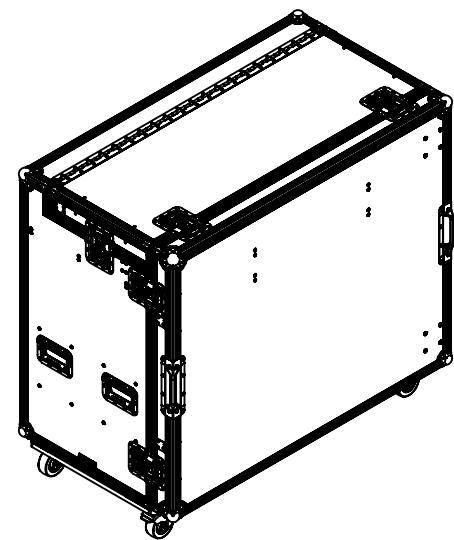

CONSTRUCION

- 12MM HIGH QUALITY PLYWOOD PANEL
- PENN ELCOM HARDWARE
- LARGE LATCHES
- EVA38 FOAM PADDING

FEATURES

- REMOVABLE DIVIDERS
- PIANO HINGE WITH GAS STRUTS
- FRONT LID THAT CAN BE USED AS TABLE

NOTES:
 UNLESS SPECIFIED IN THE DRAWING,
 ALL PRODUCTS DISPLAYED IN THIS
 DRAWING OTHER THAN THE CASE
 ITSELF IS NOT PART OF OUR PRODUCT
 OFFERING.

ESTIMATED WEIGHT (CASE ONLY):

110.93 KG

ITEM CODE:

WS-ER

DRAWN BY:

H.A

CHECKED BY:

AS

SCALE:

NTS



MAIL : sales@armorcases.com.au
 WEB : www.armorcases.com.au

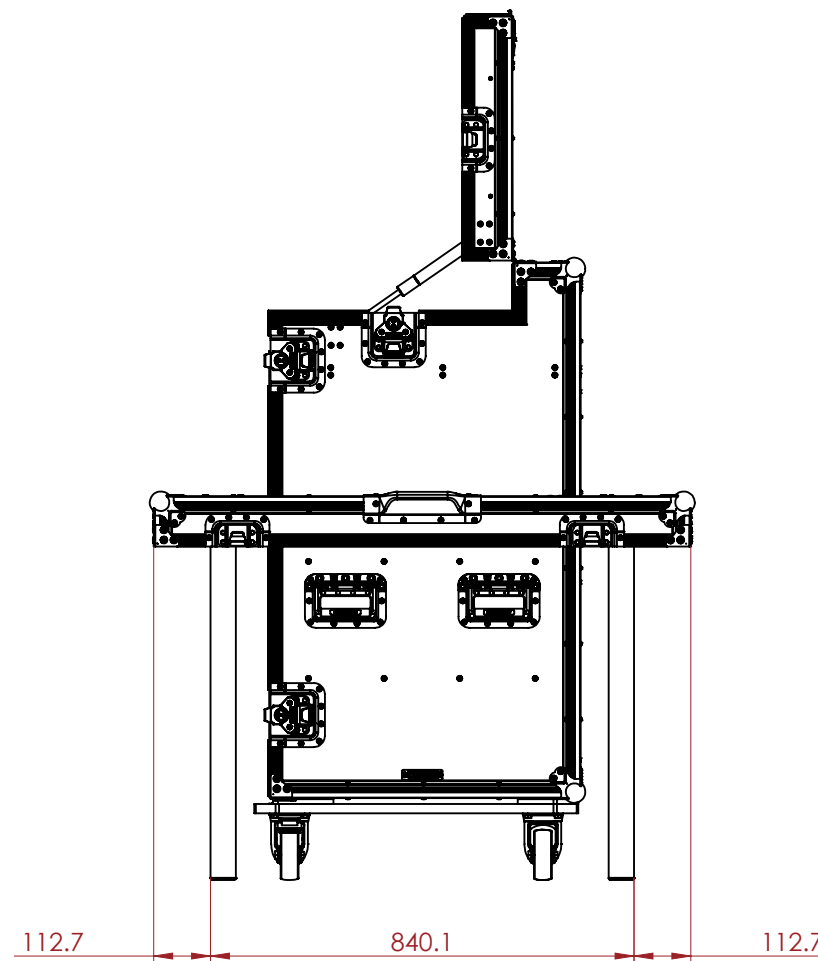
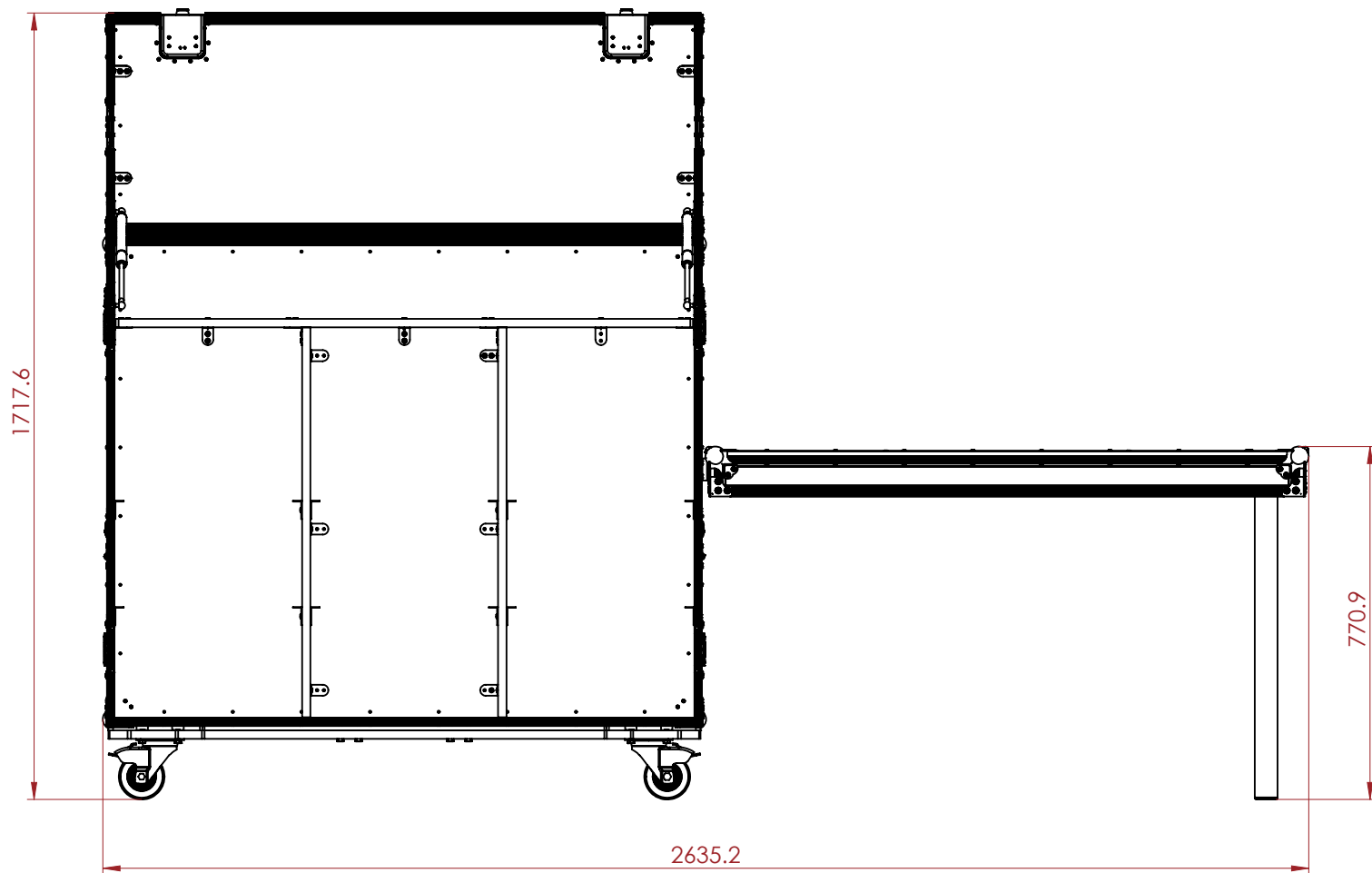
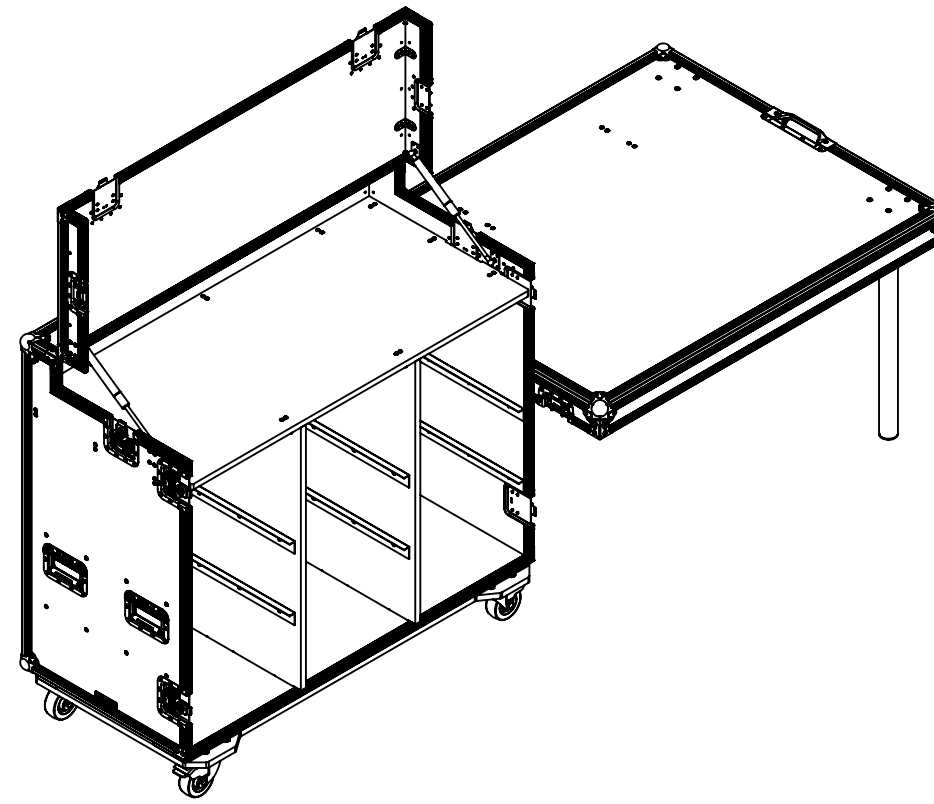
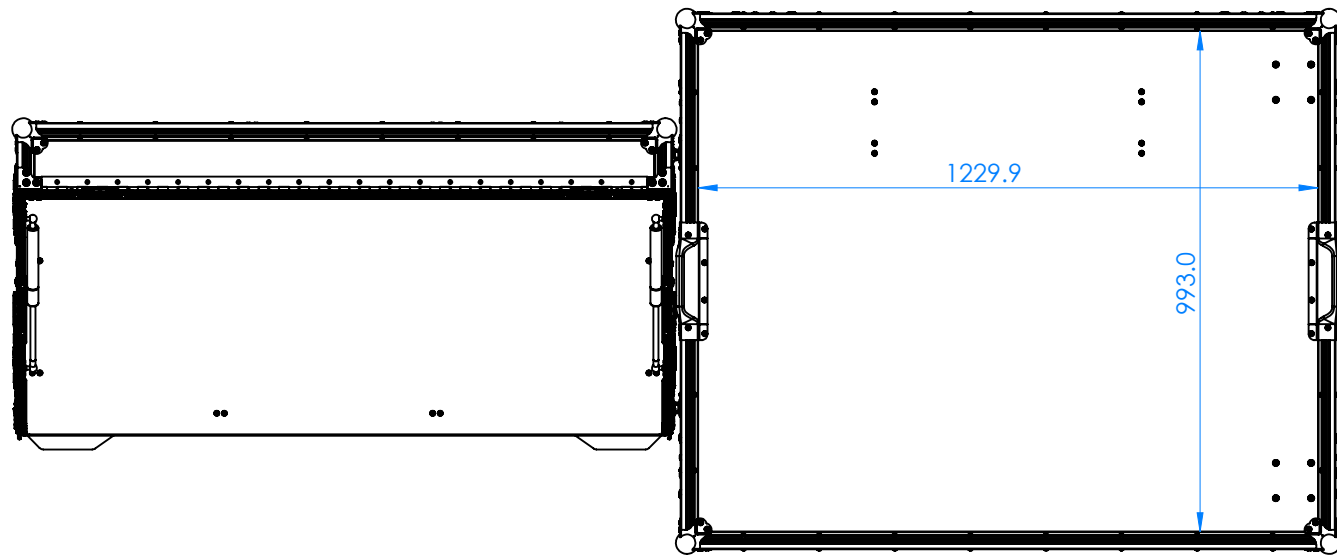

NOTES:
UNLESS SPECIFIED IN THE DRAWING,
ALL PRODUCTS DISPLAYED IN THIS
DRAWING OTHER THAN THE CASE
ITSELF IS NOT PART OF OUR PRODUCT
OFFERING.

ESTIMATED WEIGHT (CASE ONLY):

110.93 KG

ITEM CODE:

WS-ER

DRAWN BY:

H.A

CHECKED BY:

AS

SCALE:

NTS



MAIL : sales@armorcases.com.au
WEB : www.armorcases.com.au