

PRODUCT FEATURES

CONSTRUCTION

- 12MM BIRCH VENEER PLYWOOD WITH HPL EXTERIOR FACE AND PVC INTERIOR FACE
- PENN ELCOM HARDWARE

INSTALLED EQUIPMENT (INCLUDED)

- 11RU RACK STRIPS LOCATED AT THE FRONT AND BACK
- FRONT TO BACK RACK STRIP DISTANCE AT 568MM
- 3RU DRAWER
- 1U 6 WAY PDU LOCATED AT THE BACK

FEATURES

- REMOVABLE FRONT LID
- SLAM LID LOCATED AT THE BACK
- MOUNTINGS FOR YAMAHA HS5I MONITORS
- PULL OUT DRAWER TO CARRY KEYBOARD AND MOUSE
- WIRE PASSES INCLUDED FOR BETTER AND EFFICIENT WIRE MANAGEMENT
- 3X STORAGE COMPARTMENTS FOR ACCESSORIES, 600MM DEEP
- GAS STRUTS FOR EASE OF OPENING AND CLOSING

KEY MEASUREMENTS

- WORKBENCH HEIGHT AT 850MM

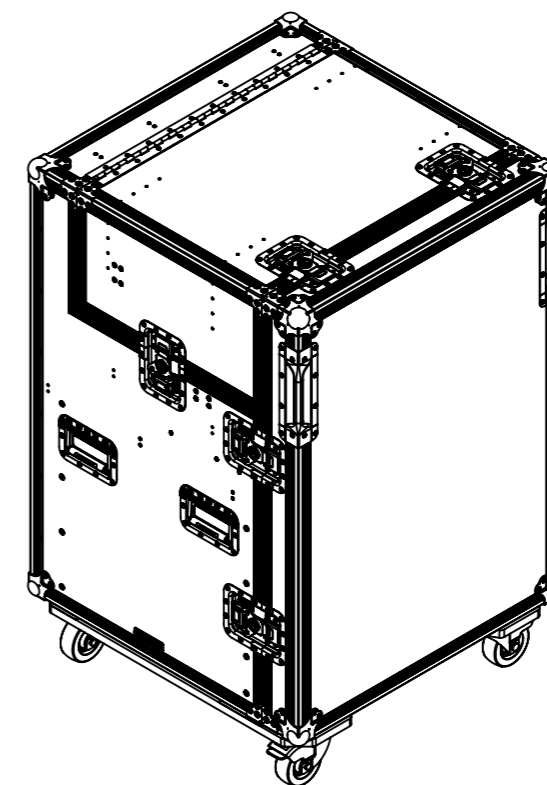
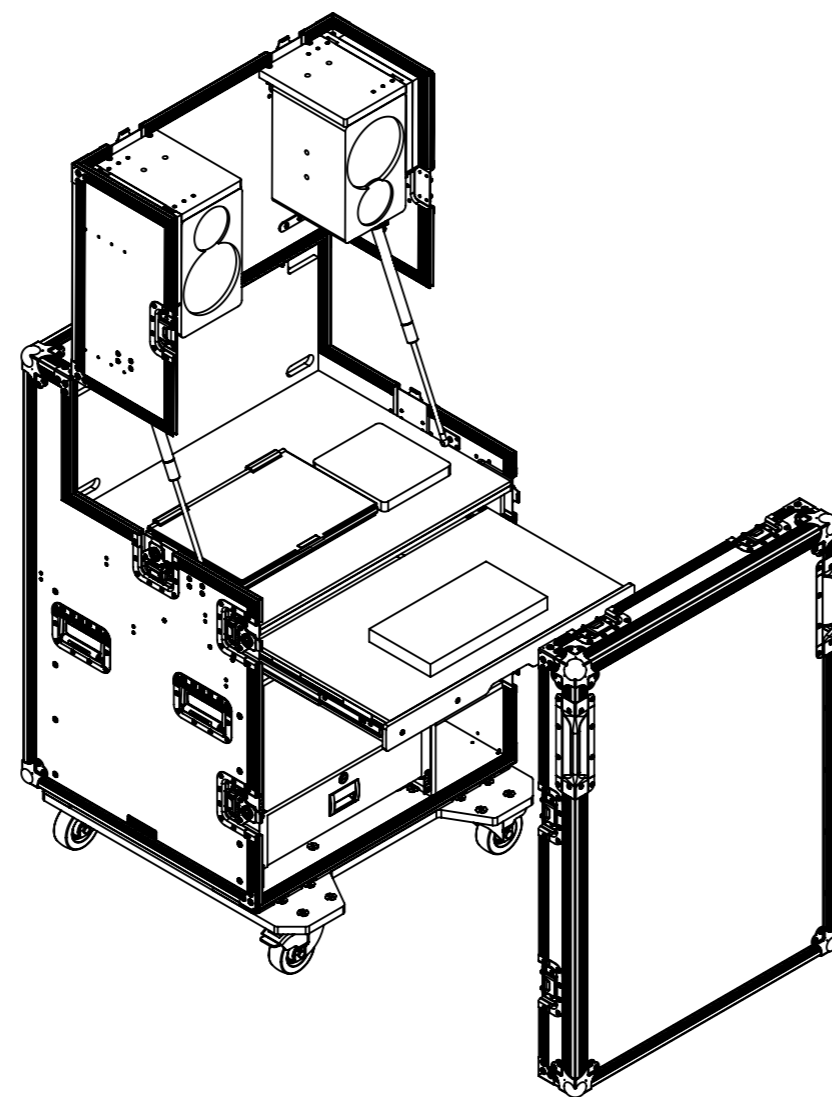
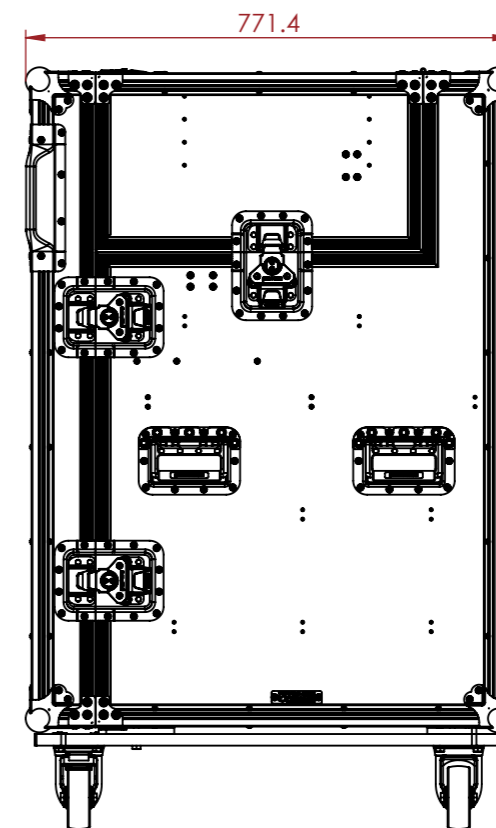
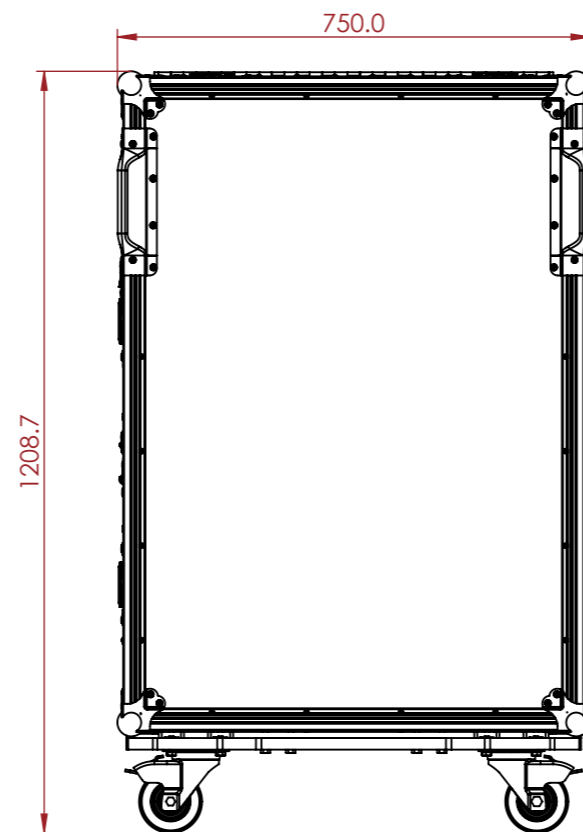

NOTES:

UNLESS SPECIFIED IN THE DRAWING, ALL PRODUCTS DISPLAYED IN THIS DRAWING OTHER THAN THE CASE ITSELF IS NOT PART OF OUR PRODUCT OFFERING.

ESTIMATED WEIGHT (CASE ONLY):

94.56 KG

ITEM CODE:

WS-VR-YHA-HS5I

DRAWN BY:

K.I

CHECKED BY:

AS

SCALE:

NTS



MAIL : sales@armorcases.com.au
WEB : www.armorcases.com.au