

PRODUCT FEATURES

CONSTRUCTION

- 12MM HIGH QUALITY DOUBLE SIDED LAMINATED BIRCH PANEL
- ARMOR HARDWARE

INSTALLED EQUIPMENT INCLUDED :

INCLUDED :

- 16RU AND 11RU RACK STRIPS LOCATED AT FRONT AND BACK
- 1X 2RU TRAY, 3X 2RU DRAWER
- 1X PUNCHED PATCH PANEL
- 1X POWERBOARD
- NEUTRIK CONNECTORS : 1X HDMI, 5X RJ45

NOT INCLUDED:

- ALLEN & HEATH AVANTIS CONSOLE

FEATURES:

- FRONT LID CAN CAN ACT AS TABLE FOR ADDITIONAL WORKSPACE
- SLAM LID AND HATCH DOOR LOCATED AT THE BACK

KEY MEASUREMENTS:

- FOLDABLE TABLE TOP HEIGHT 850MM
- FRONT AND REAR RACK STRIPS DISTANCE 505.3MM
- REAR RACK STRIPS TO REAR PANEL 150MM

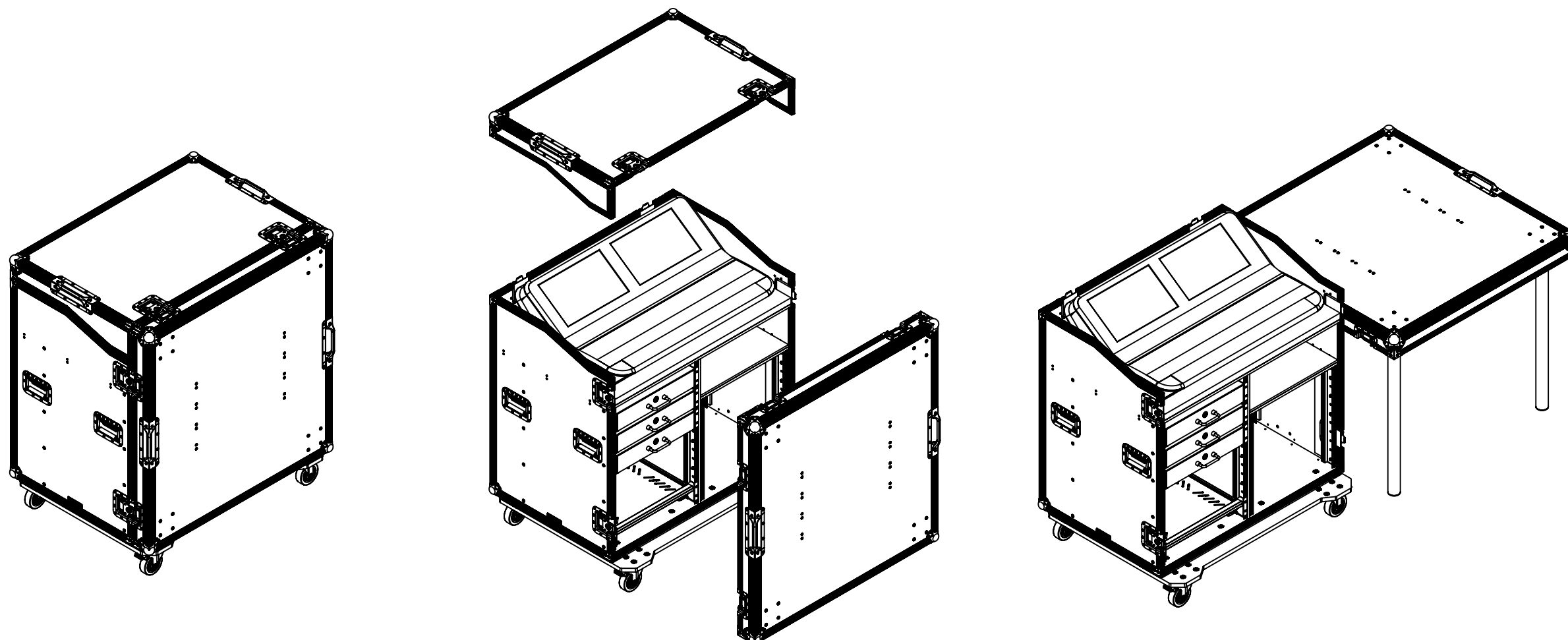
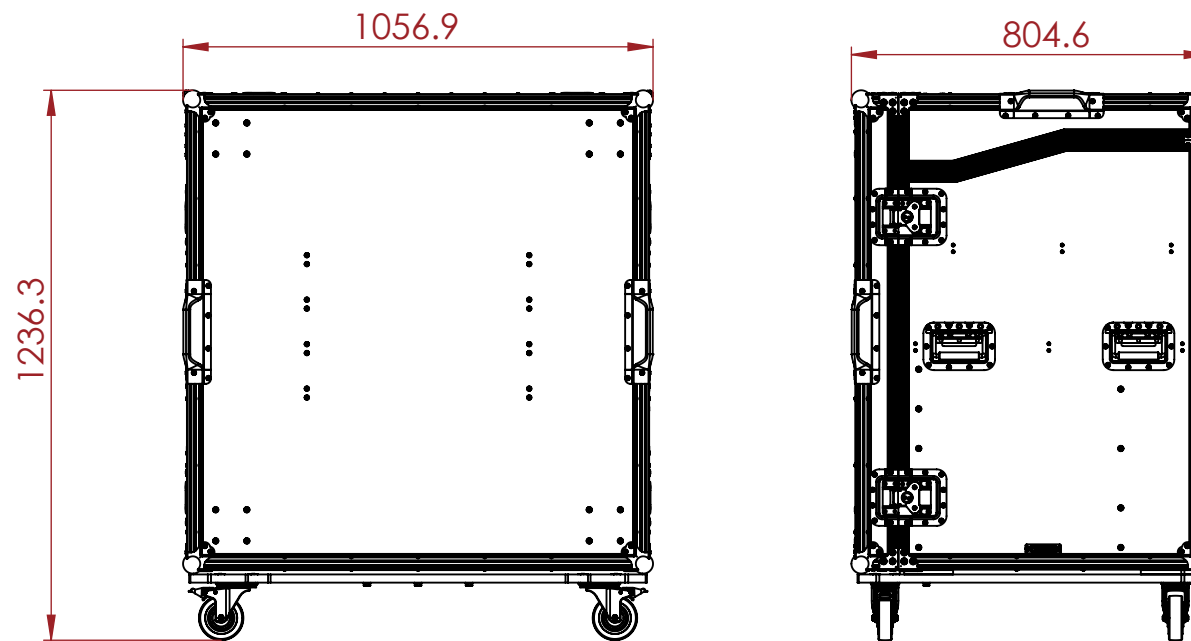

NOTES:

UNLESS SPECIFIED IN THE DRAWING, ALL PRODUCTS DISPLAYED IN THIS DRAWING OTHER THAN THE CASE ITSELF IS NOT PART OF OUR PRODUCT OFFERING.

REV	DESCRIPTION	DATE
0	ORIGINAL ISSUE	07/03/2024

ESTIMATED WEIGHT (CASE ONLY):

106.82 KG

ITEM CODE:

WS-AX-AH-AVANT

DRAWN BY:

RP

CHECKED BY:

AS

SCALE:

NTS



MAIL : sales@armorcases.com.au
 WEB : www.armorcases.com.au