

PRODUCT FEATURES

CONSTRUCTION

- 9MM BIRCH VENEER PLYWOOD WITH HPL EXTERIOR FACE AND PVC INTERIOR FACE
- ARMOR HARDWARE

INSTALLED EQUIPMENT (INCLUDED)

- 2X 1RU RACK STRIPS
- 1X RACK SHELF

INSTALLED EQUIPMENT (NOT INCLUDED)

- BLACKMAGIC DESIGN SMARTVIEW 4K
- BLACKMAGIC DESIGN ATEM MINI EXTREME/EXTREME ISO
- BLACKMAGIC DESIGN STUDIO CONVERTER (CINSTUDMFT-H-SC)

FEATURES

- TORQUE HINGED FRONT LID
- REMOVABLE REAR LID
- RACK MOUNTED MONITOR

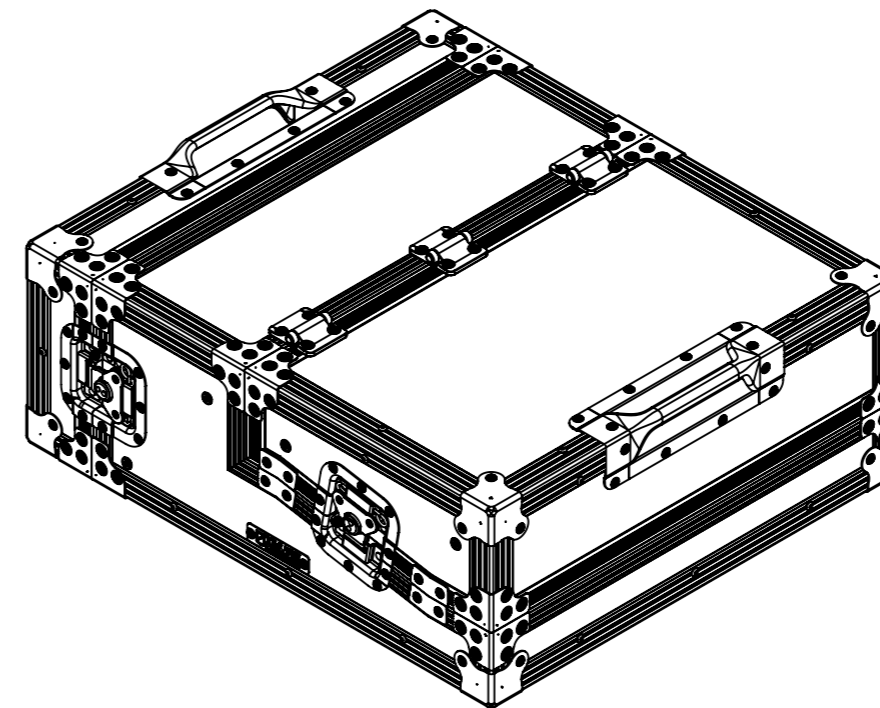
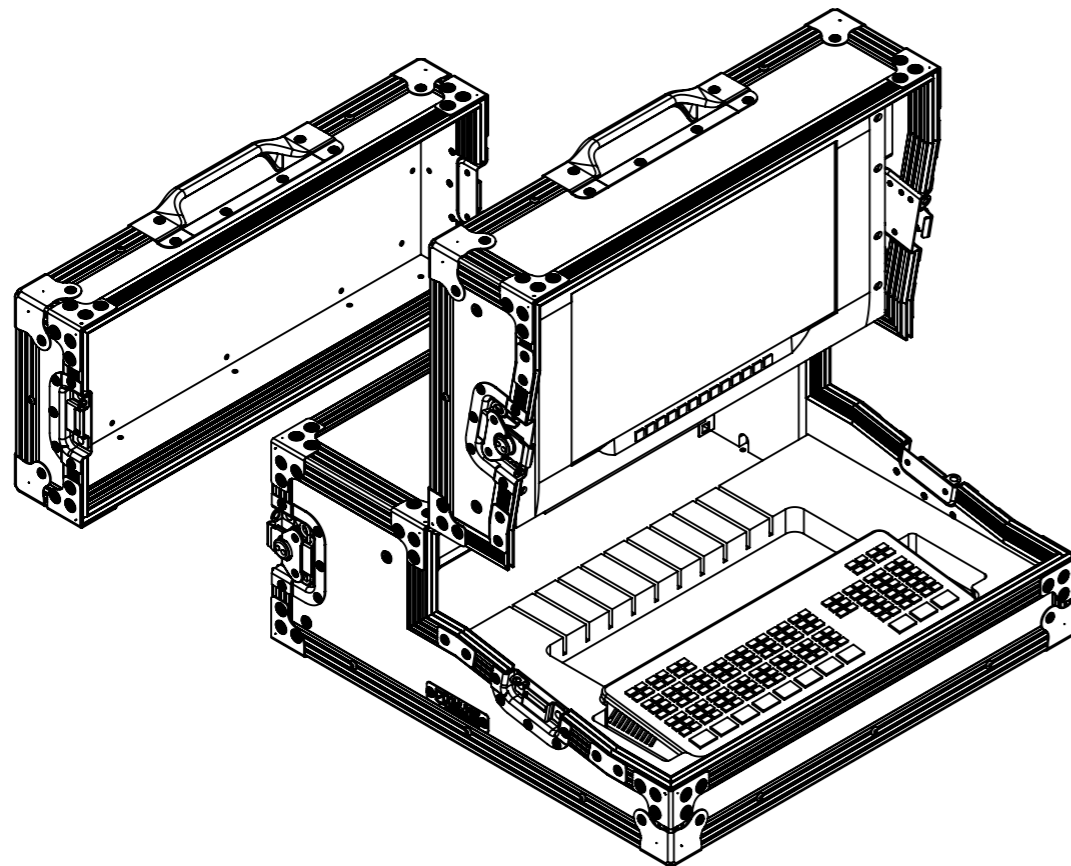
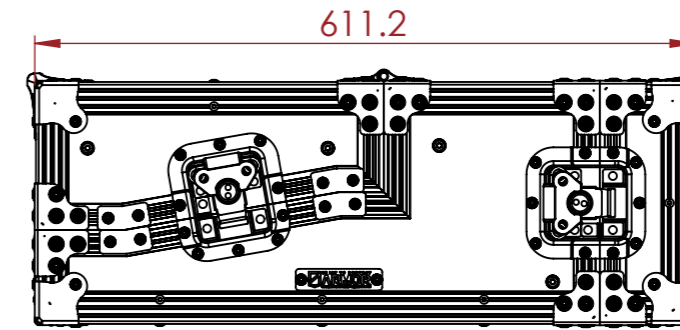
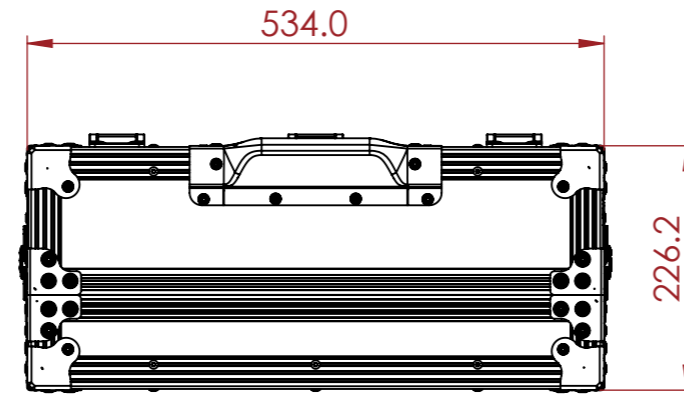

NOTES:

UNLESS SPECIFIED IN THE DRAWING, ALL PRODUCTS DISPLAYED IN THIS DRAWING OTHER THAN THE CASE ITSELF IS NOT PART OF OUR PRODUCT OFFERING.

ESTIMATED WEIGHT (CASE ONLY):

13.85 KG

ITEM CODE:

SWIT-BM-ATEM-ME-R

DRAWN BY:

RP

CHECKED BY:

AS

SCALE:

NTS



MAIL : sales@armorcases.com.au
WEB : www.armorcases.com.au