

# PRODUCT FEATURES

## CONSTRUCTION

- 9MM BIRCH VENEER PLYWOOD WITH HPL EXTERIOR FACE AND PVC INTERIOR FACE
- ARMOR HARDWARE

## FEATURES

- STORAGE FOR RIGTEC X10 PROJECTOR FRAME
- STORAGE FOR RIGTEC X10 STANDARD ATOM GRIP
- STORAGE FOR 2X LENS
- LABEL DISH FOR EASE OF RECOGNITION
- CASTOR DISH FOR EASE OF STACKING

NOTES:  
UNLESS SPECIFIED IN THE DRAWING,  
ALL PRODUCTS DISPLAYED IN THIS  
DRAWING OTHER THAN THE CASE  
ITSELF IS NOT PART OF OUR PRODUCT  
OFFERING.

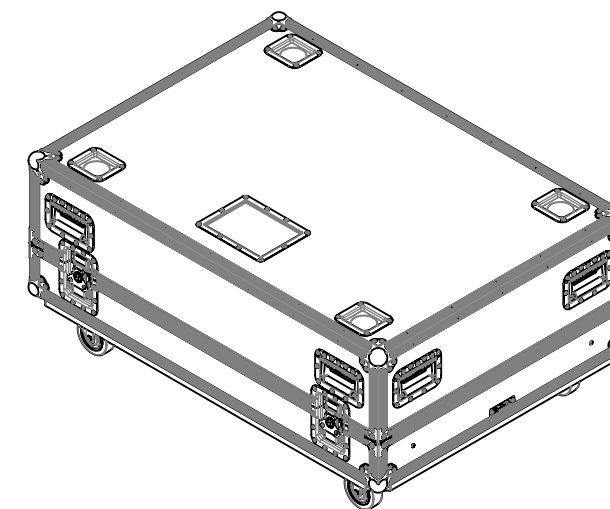
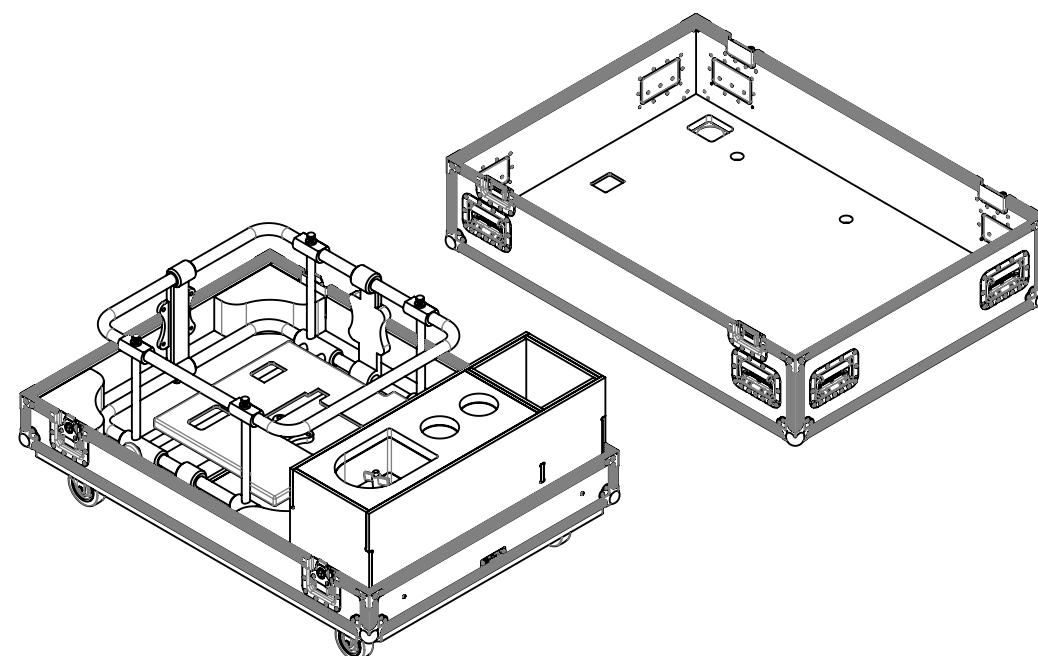
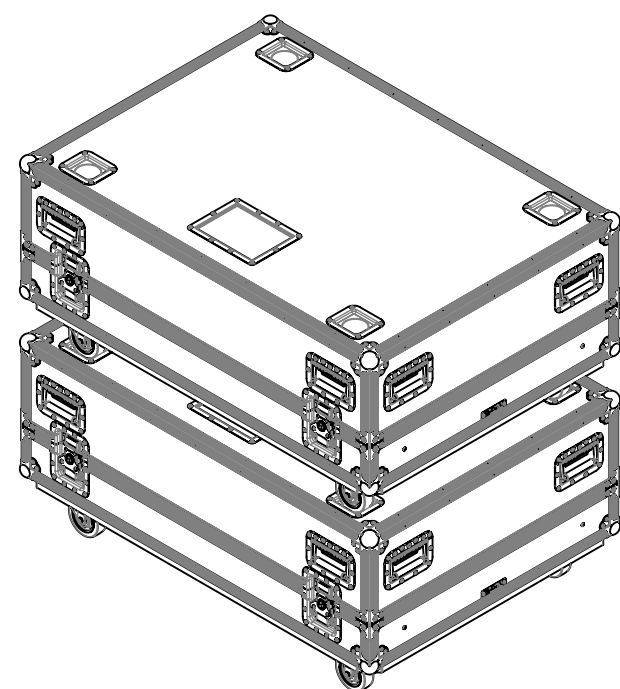
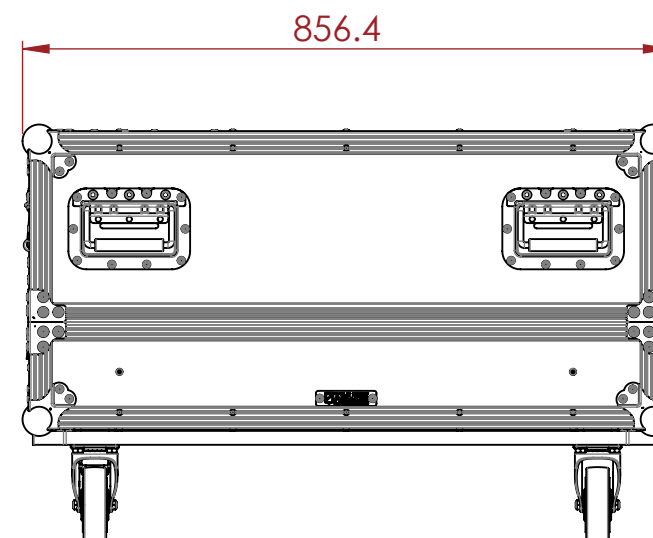
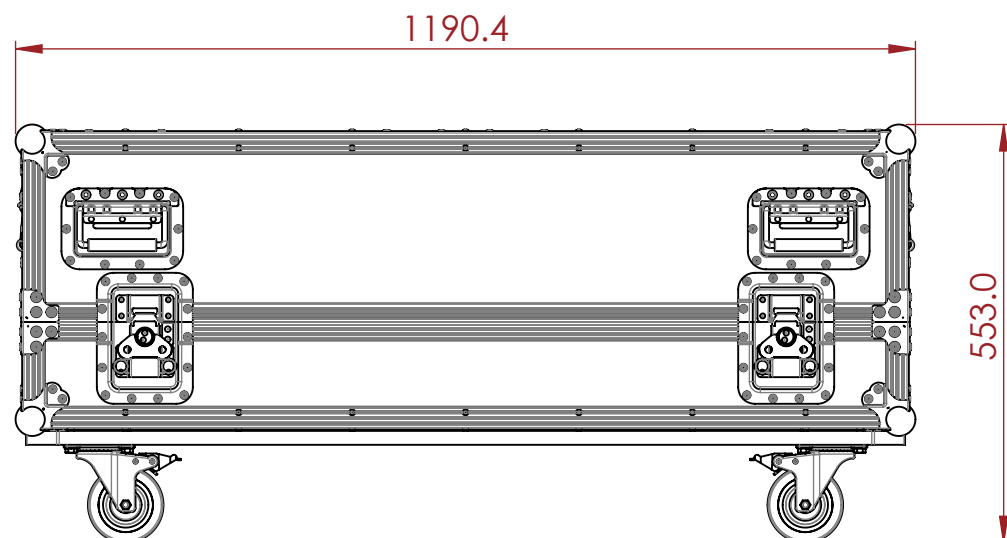

ESTIMATED WEIGHT (CASE ONLY):

59.81 KG

ITEM CODE:

PJTR-RIGTEC-X10

DRAWN BY:

K.I

CHECKED BY:

AS

SCALE:

NTS



MAIL : [sales@armorcases.com.au](mailto:sales@armorcases.com.au)  
WEB : [www.armorcases.com.au](http://www.armorcases.com.au)