

SECTION A-A
SCALE 1 : 8

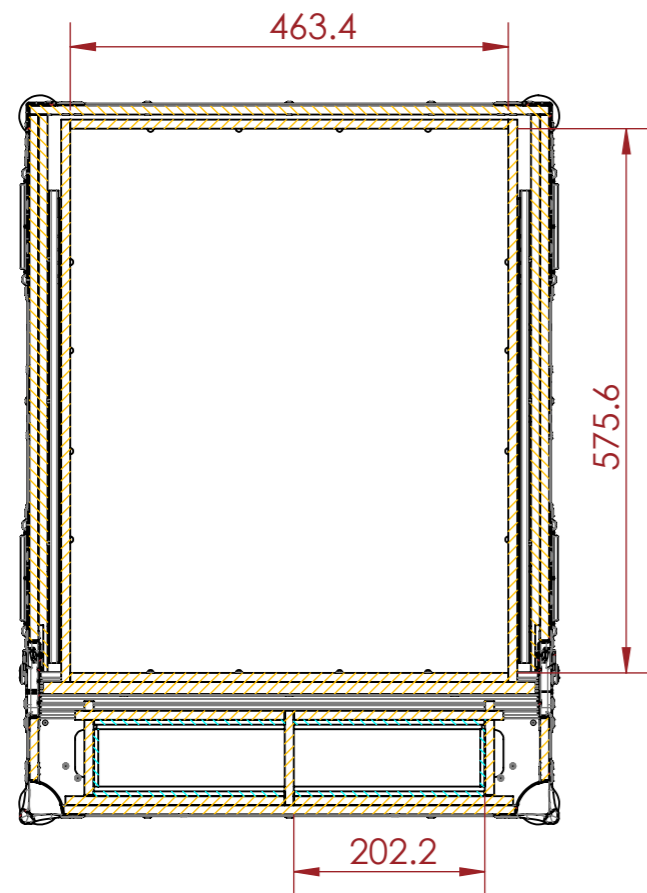

SECTION B-B
SCALE 1 : 8

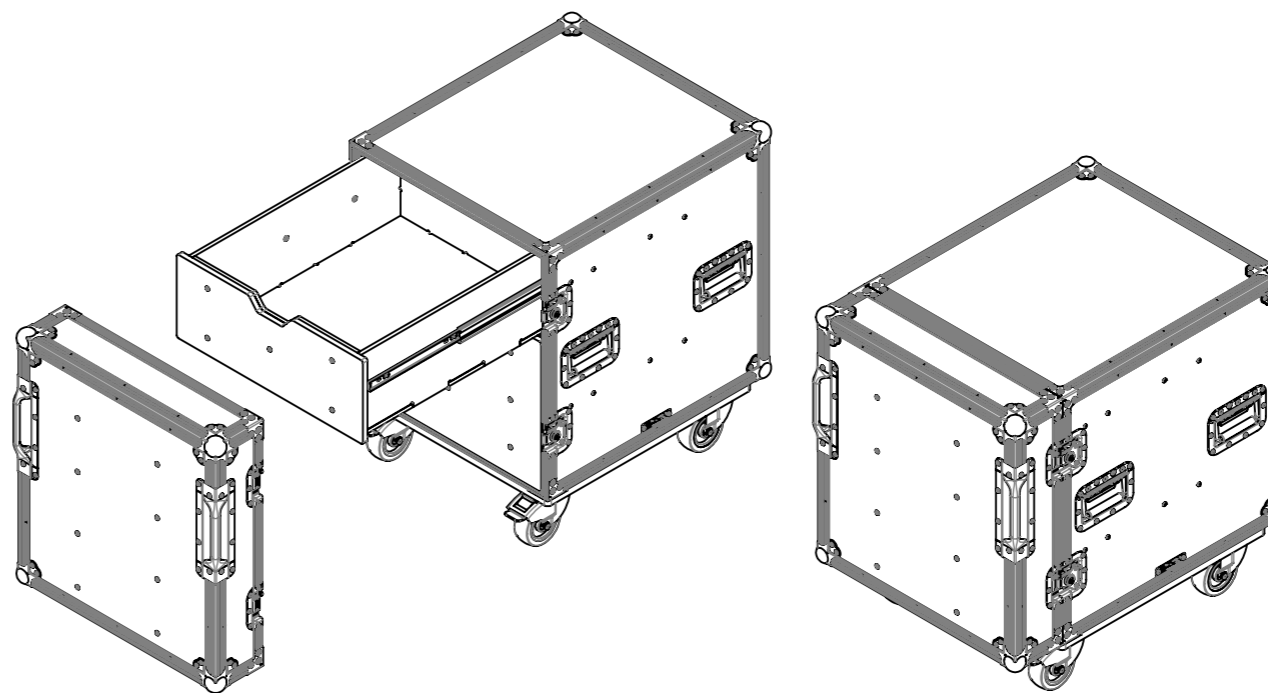

NOTES:
UNLESS SPECIFIED IN THE DRAWING,
ALL PRODUCTS DISPLAYED IN THIS
DRAWING OTHER THAN THE CASE
ITSELF IS NOT PART OF OUR PRODUCT
OFFERING.

ESTIMATED WEIGHT (CASE ONLY):

55.7 KG

ITEM CODE:

UTL-DR2-WM

DRAWN BY:

K.I

CHECKED BY:

AS

SCALE:

NTS



MAIL : sales@armorcases.com.au
WEB : www.armorcases.com.au