

# PRODUCT FEATURES

## CONSTRUCTION

- 12MM HIGH QUALITY DOUBLE SIDED PLYWOOD PANEL
- PENN ELCOM HARDWARE

## FEATURES

- STORAGE ON THE BOTTOM OF CASE FOR ACCESSORIES
- ENGRAVED LOGO AND MADEL NAME ON TOP OF LID.

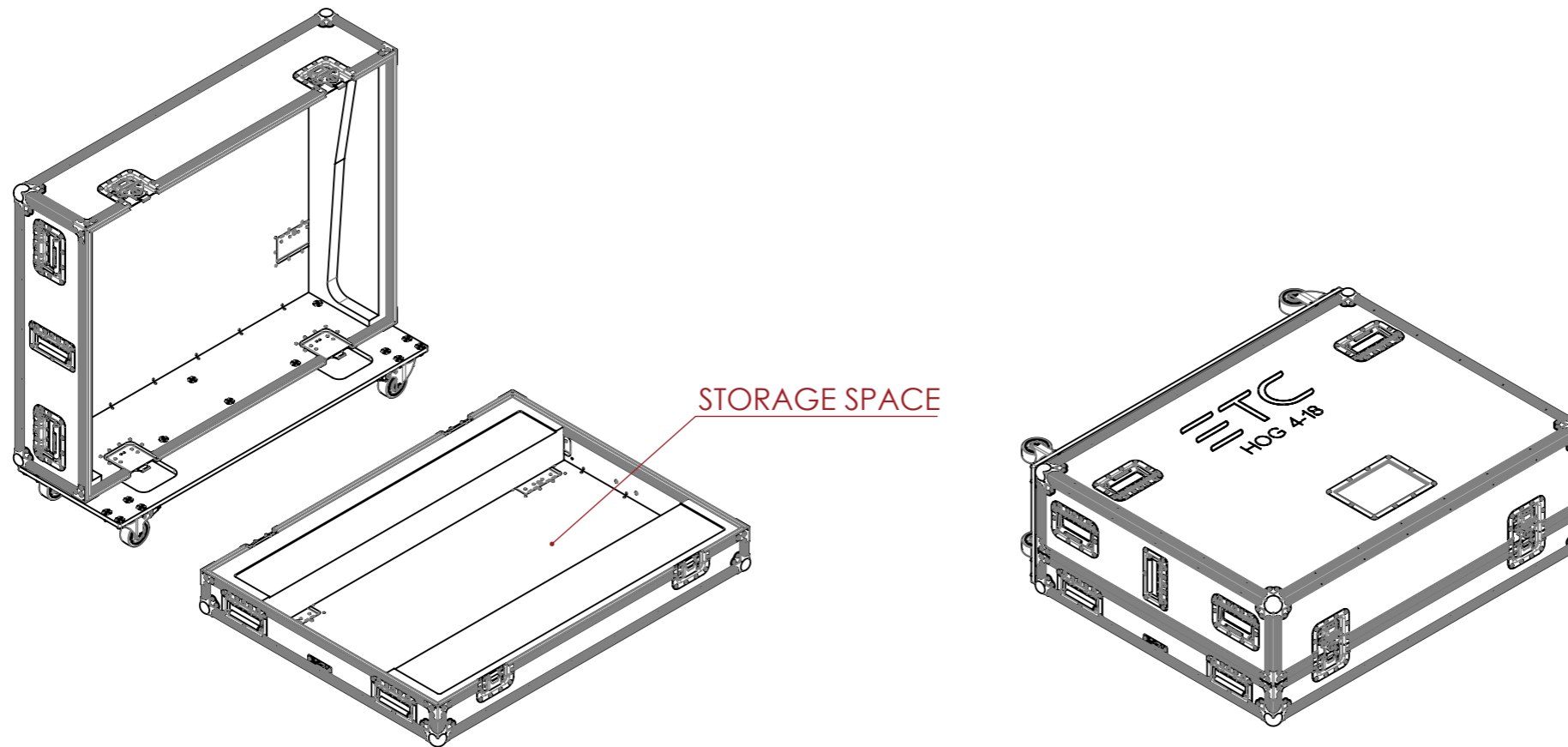
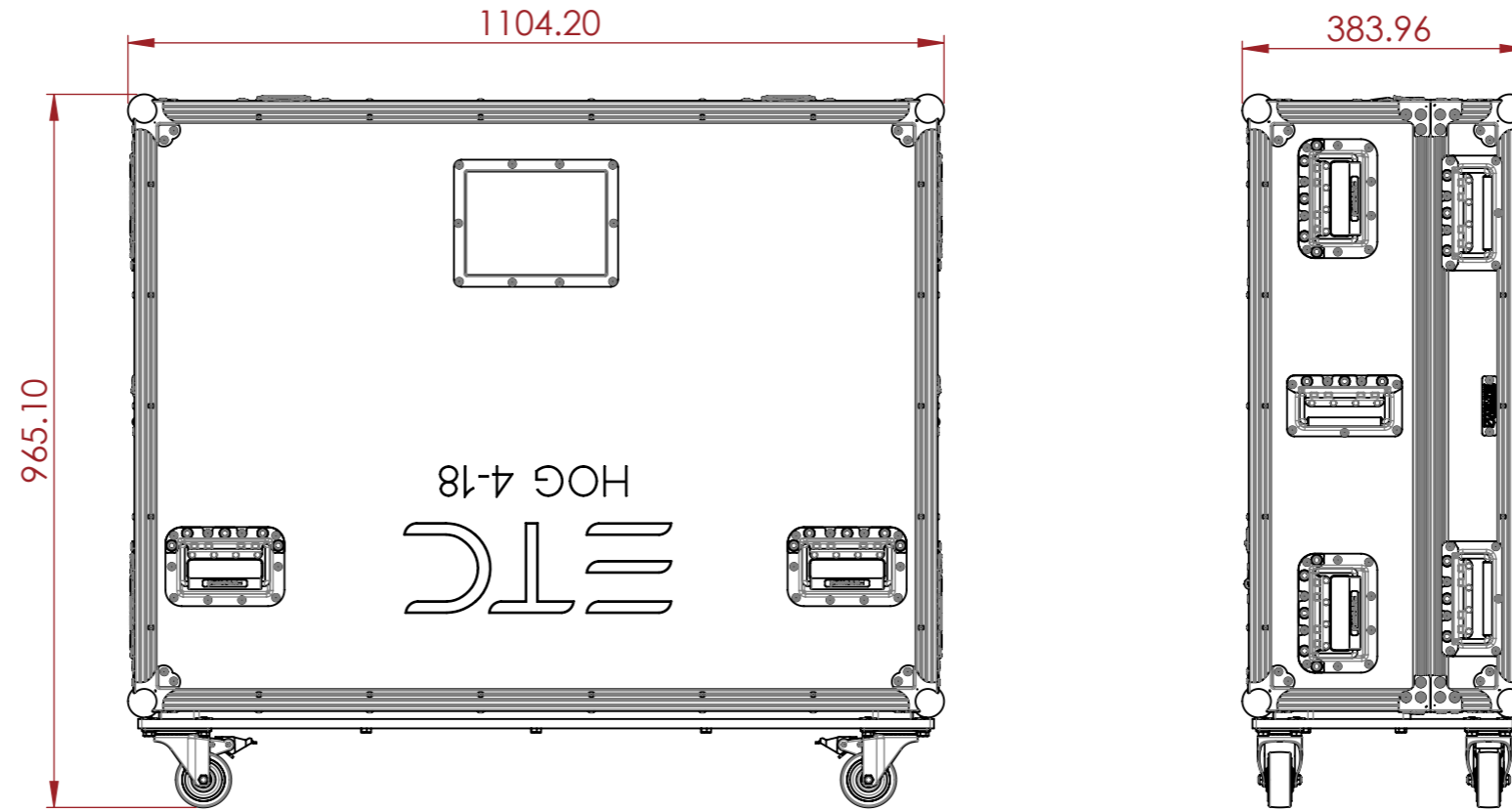

NOTES:  
UNLESS SPECIFIED IN THE DRAWING,  
ALL PRODUCTS DISPLAYED IN THIS  
DRAWING OTHER THAN THE CASE  
ITSELF IS NOT PART OF OUR PRODUCT  
OFFERING.

ESTIMATED WEIGHT (CASE ONLY):

47.95 KG

ITEM CODE:

LXCTRL-ETC-H4-18

DRAWN BY:

K.I

CHECKED BY:

AS

SCALE:

NTS



MAIL : [sales@armorcases.com.au](mailto:sales@armorcases.com.au)  
WEB : [www.armorcases.com.au](http://www.armorcases.com.au)