

PRODUCT FEATURES

CONSTRUCTION

- 12MM HIGH QUALITY DOUBLE SIDED PLYWOOD PANEL
- PENN ELCOM HARDWARE

FEATURES

- STORAGE ON THE BOTTOM OF THE CASE FOR ACCESSORIES
- ENGRAVED LOGO AND MODEL NAME ON TOP OF THE LID.

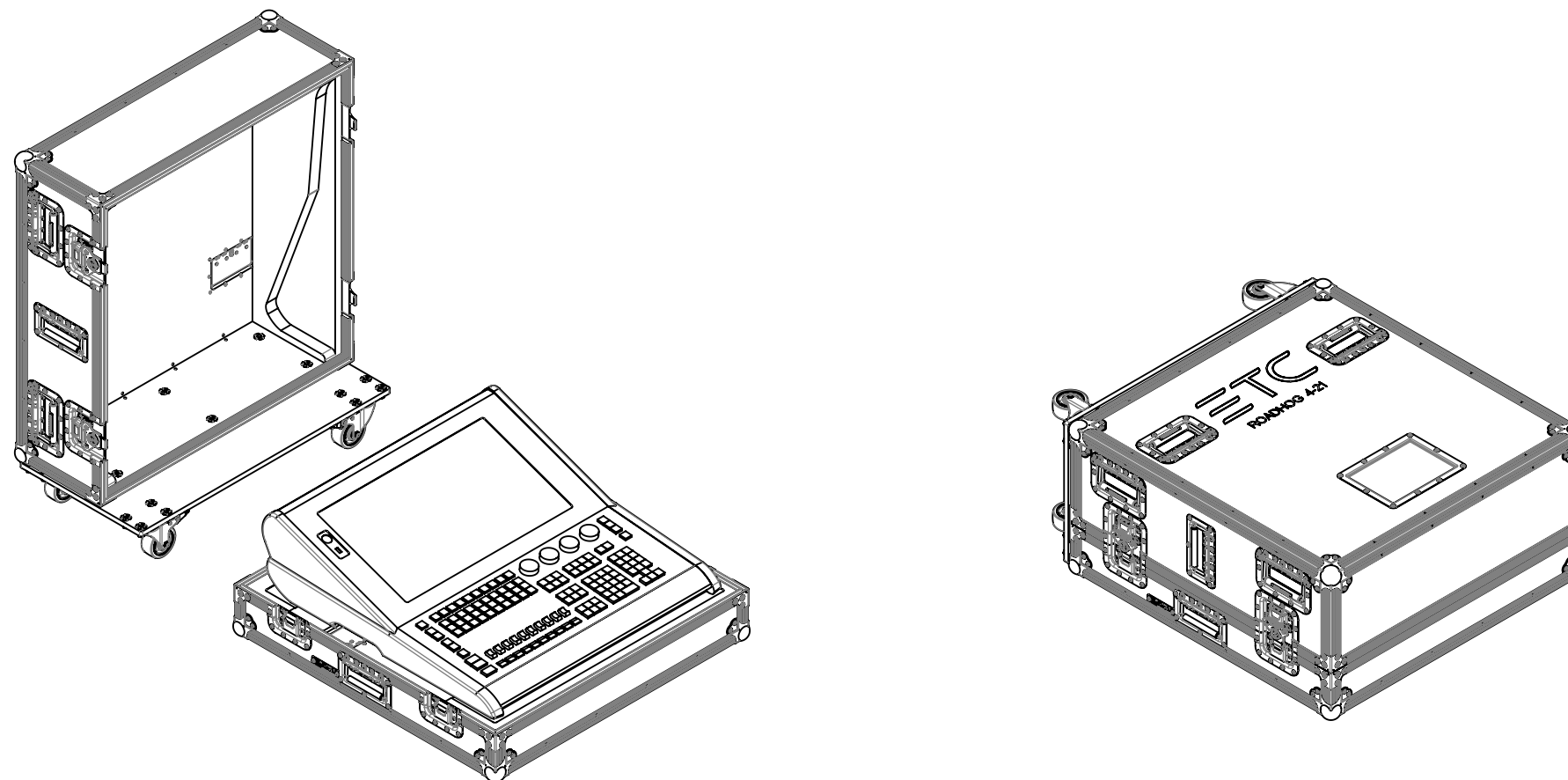
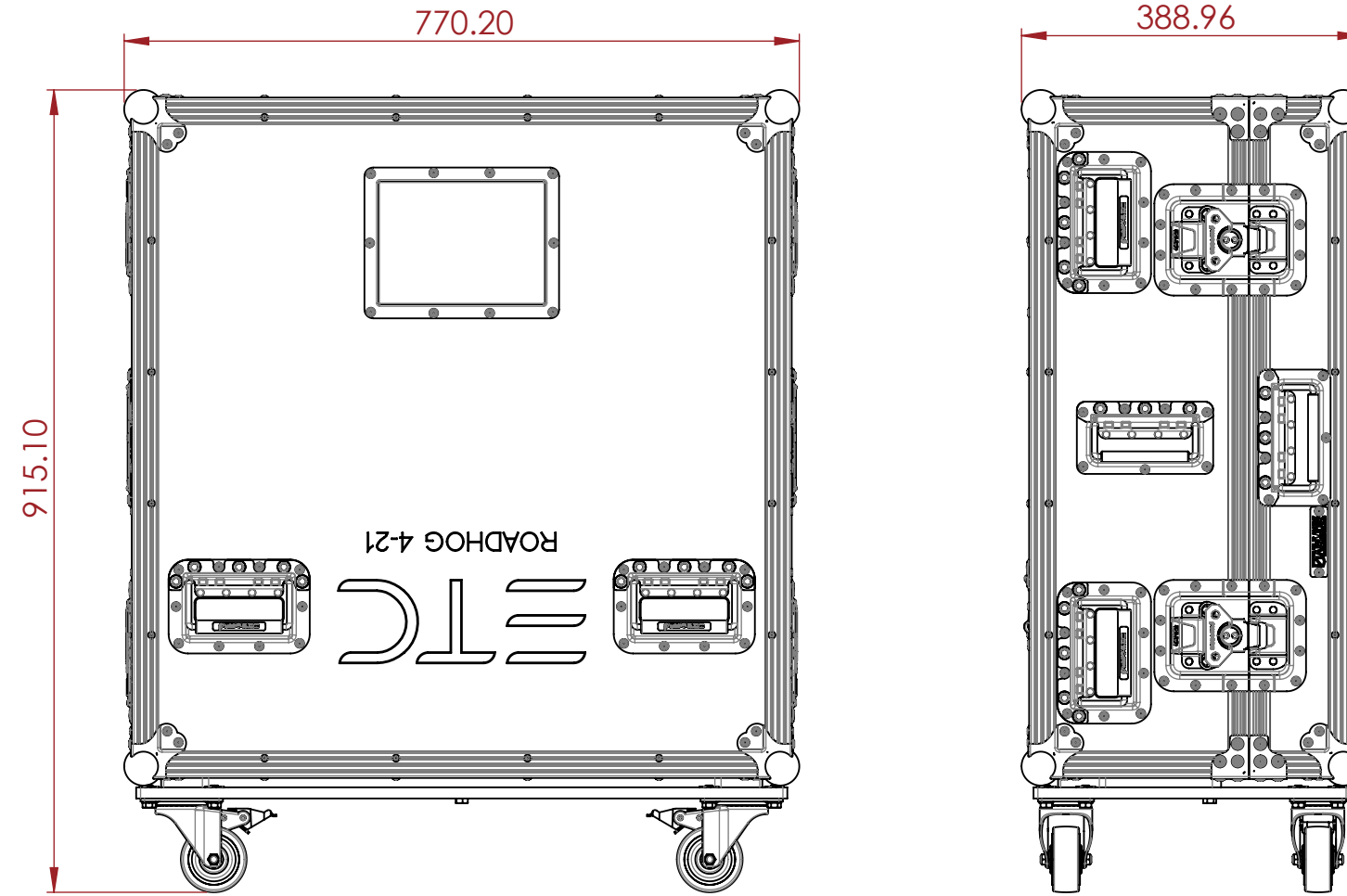

NOTES:
UNLESS SPECIFIED IN THE DRAWING,
ALL PRODUCTS DISPLAYED IN THIS
DRAWING OTHER THAN THE CASE
ITSELF IS NOT PART OF OUR PRODUCT
OFFERING.

ESTIMATED WEIGHT (CASE ONLY):

36.73 KG

ITEM CODE:

LXCTRL-ETC-RH4-21

DRAWN BY:

K.I

CHECKED BY:

AS

SCALE:

NTS



MAIL : sales@armorcases.com.au
WEB : www.armorcases.com.au