

PRODUCT FEATURES

CONSTRUCTION

- 9MM BIRCH VENEER PLYWOOD WITH HPL EXTERIOR FACE AND PVC INTERIOR FACE
- PENN ELCOM HARDWARE

INSTALLED EQUIPMENT (INCLUDED)

- NONE

FEATURES

- GENERAL STORAGE FOR ACCESSORIES

KEY MEASUREMENTS

- NONE

DESIGN SPECIFICATIONS

- NOT APPLICABLE

NOTE

- ALIGN CLAMP WITH OMEGA BRACKET BEFORE CLOSING THE CASE

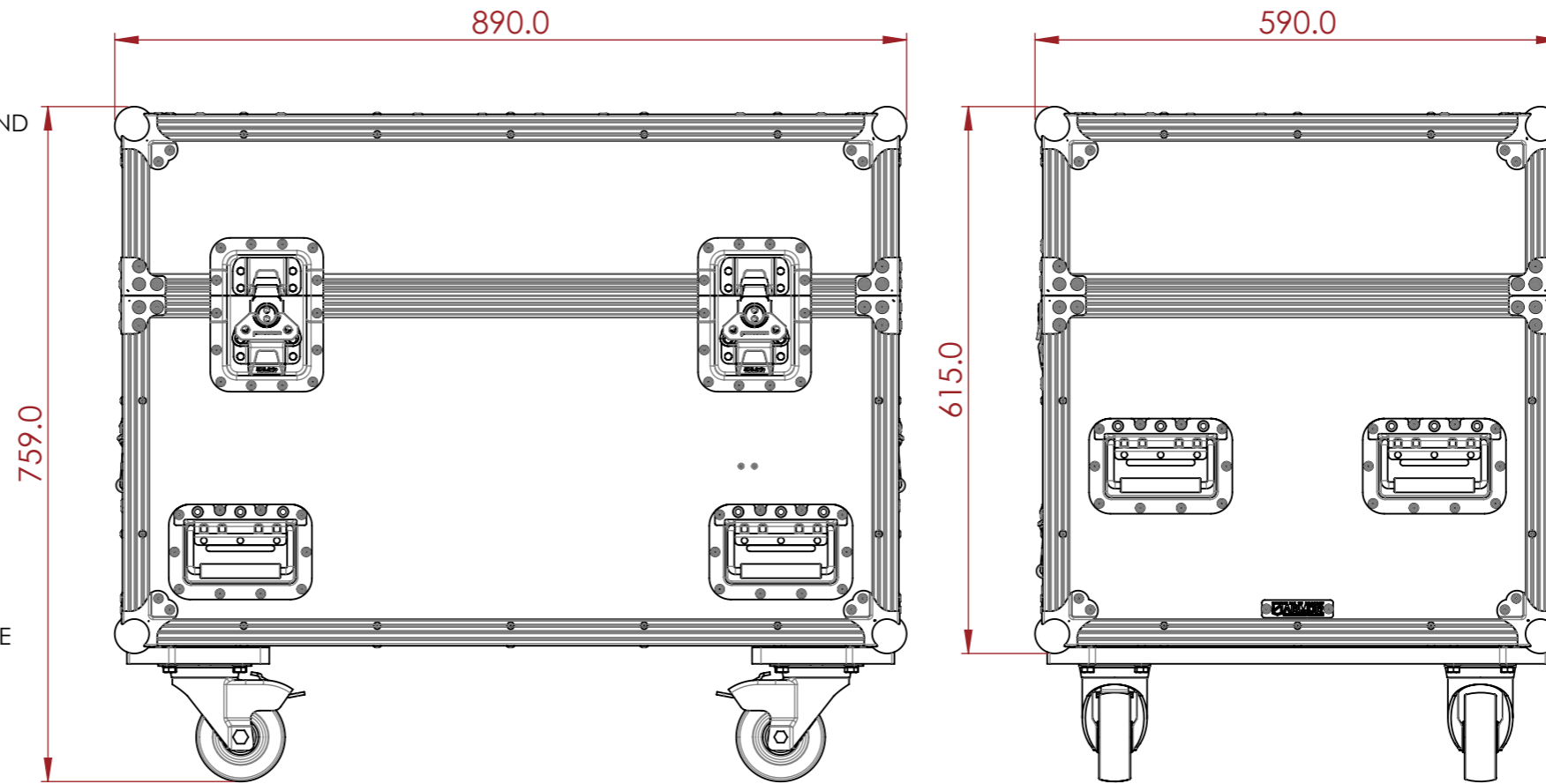

NOTES:
UNLESS SPECIFIED IN THE DRAWING,
ALL PRODUCTS DISPLAYED IN THIS
DRAWING OTHER THAN THE CASE
ITSELF IS NOT PART OF OUR PRODUCT
OFFERING.

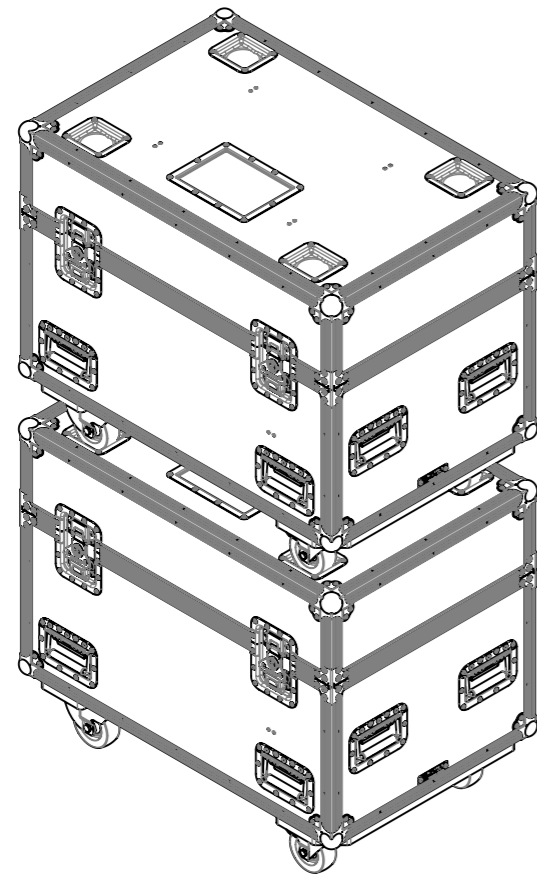

Robin LEDBeam 150
(DIMENSIONS NEED TO BE CONFIRMED BEFORE
MANUFACTURING)

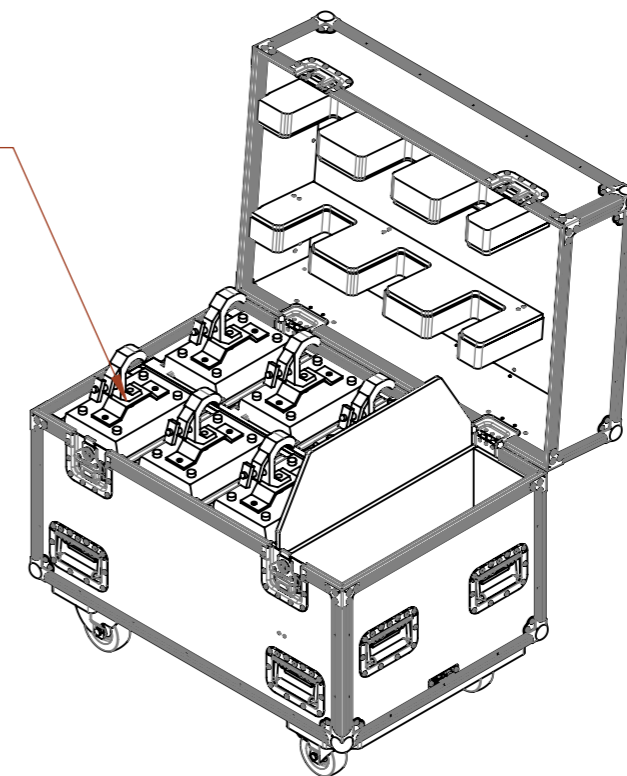
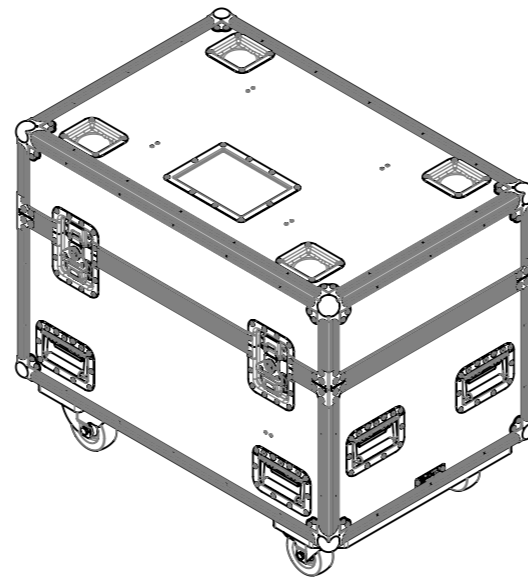

ESTIMATED WEIGHT (CASE ONLY):

47.11 KG

ITEM CODE:

LXMH-ROBE-LEDB150

DRAWN BY:

HA

CHECKED BY:

AS

SCALE:

NTS



MAIL : sales@armorcases.com.au
WEB : www.armorcases.com.au