

PRODUCT FEATURES

CONSTRUCTION

- 12MM BIRCH VENEER PLYWOOD WITH HPL EXTERIOR FACE AND PVC INTERIOR FACE
- PENN ELCOM HARDWARE

INSTALLED EQUIPMENT (INCLUDED)

- 28 RU RACK STRIPS INSIDE THE BASE

FEATURES

- NONE

KEY MEASUREMENTS

- NONE

DESIGN SPECIFICATIONS

- CASE HAS RACK STRIPS ON BOTH FRONT AND BACK TO INSTALL EQUIPMENT

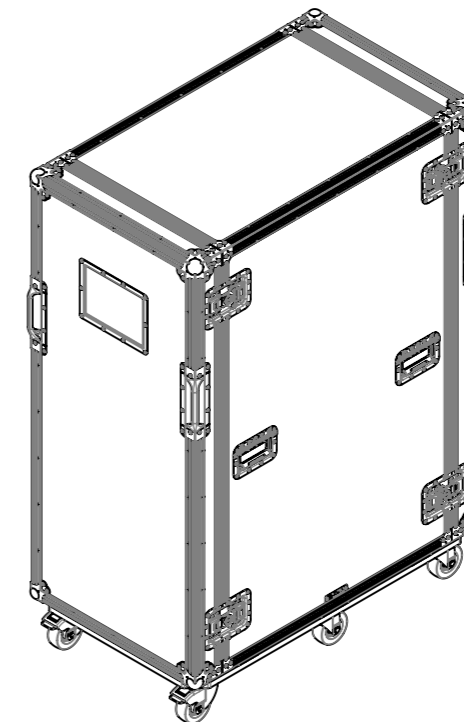
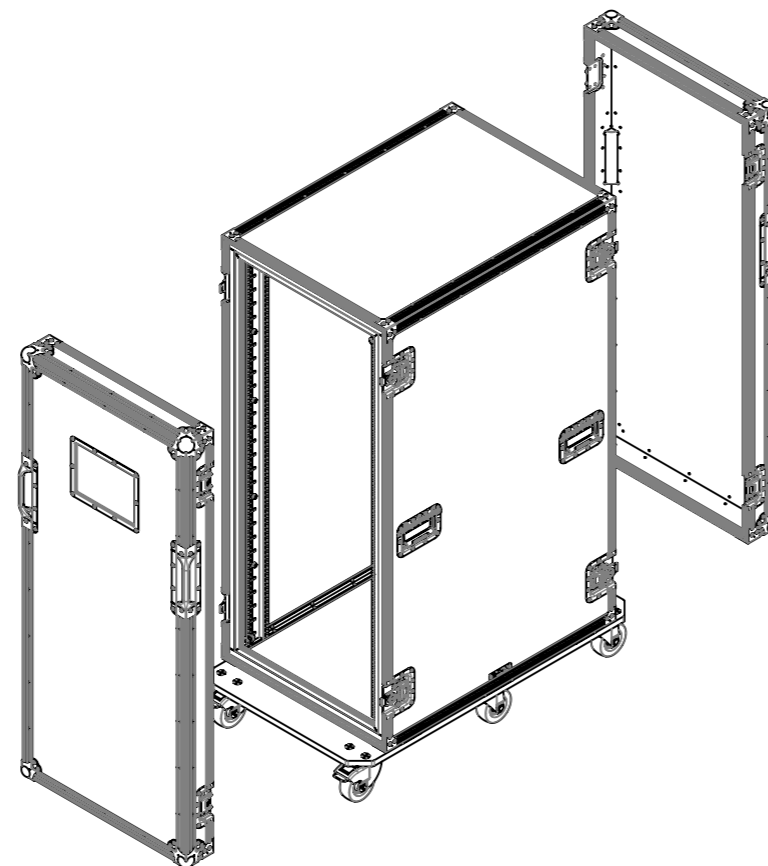
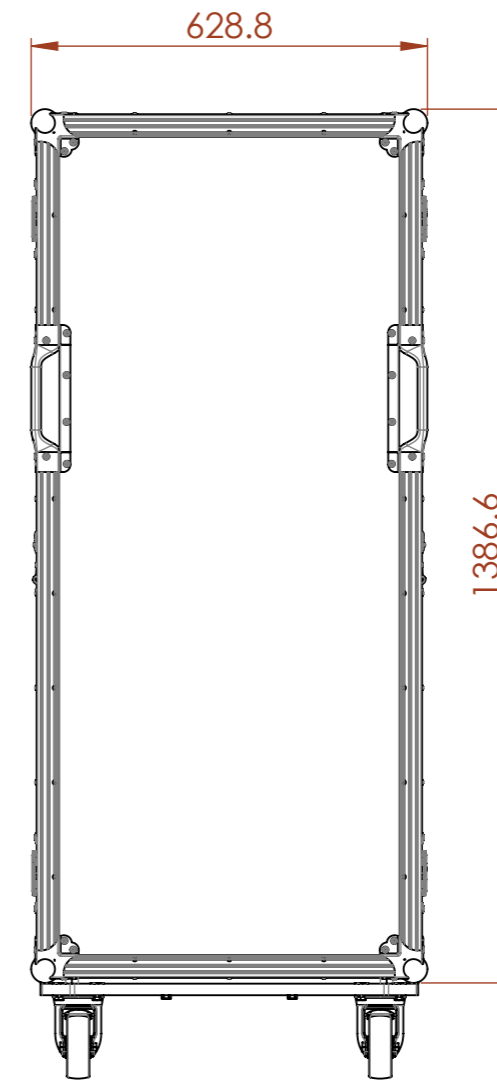
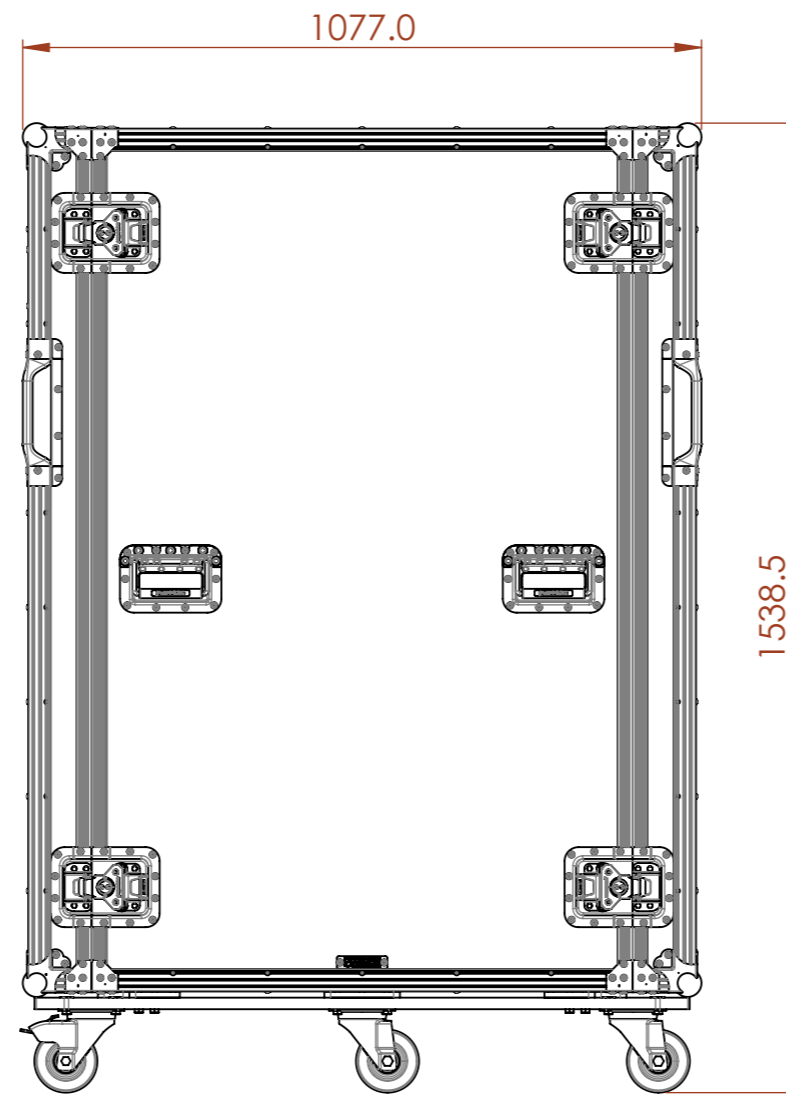

NOTES:

UNLESS SPECIFIED IN THE DRAWING, ALL PRODUCTS DISPLAYED IN THIS DRAWING OTHER THAN THE CASE ITSELF IS NOT PART OF OUR PRODUCT OFFERING.

ESTIMATED WEIGHT (CASE ONLY):

120.47 KG

ITEM CODE:

RFK-28U-800

DRAWN BY:

HA

CHECKED BY:

AS

SCALE:

NTS



MAIL : sales@armorcases.com.au

WEB : www.armorcases.com.au