

PRODUCT FEATURES

**CONSTRUCTION**

- 12MM BIRCH VENEER PLYWOOD WITH HPL EXTERIOR FACE AND PVC INTERIOR FACE
- PENN ELCOM HARDWARE

**FEATURES**

- STORAGE SPACE FOR 2X DB VIO X310 SPEAKERS
- ACCESSORIES STORAGE COMPARTMENT FOR 2X VERTICAL BRACKETS -HORIZONTAL BRACKETS NOT SUPPORTED.
- CASTOR DISHES FOR EASE OF STACKING

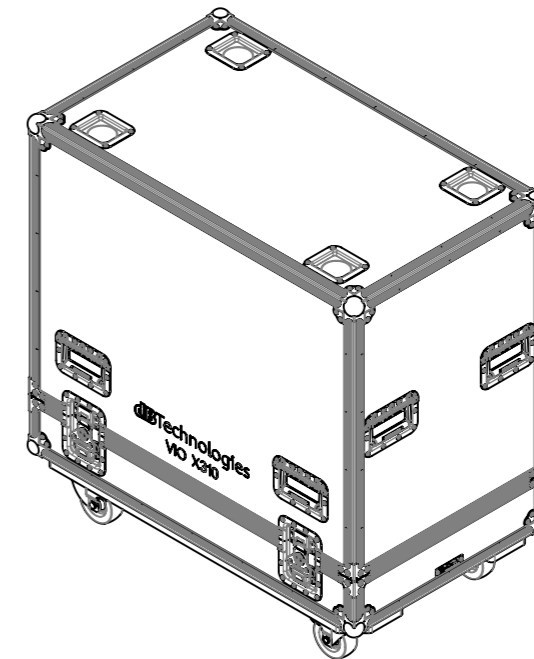
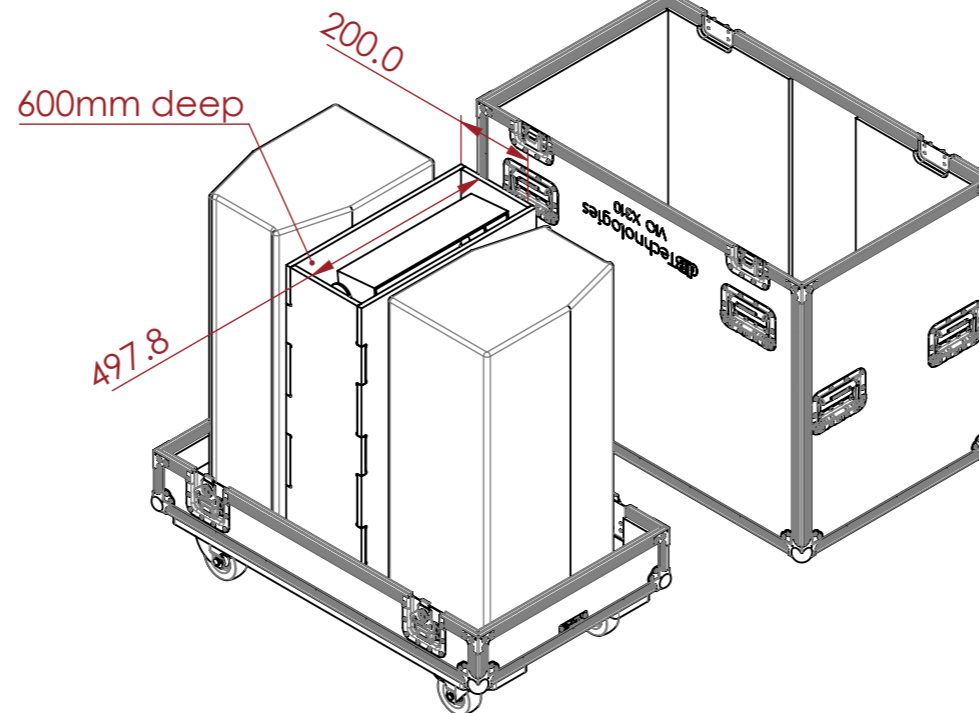
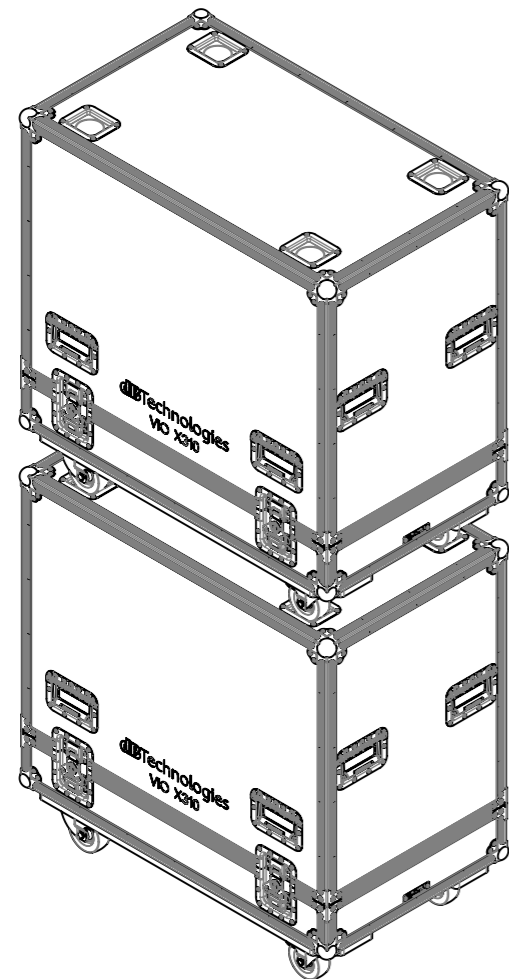
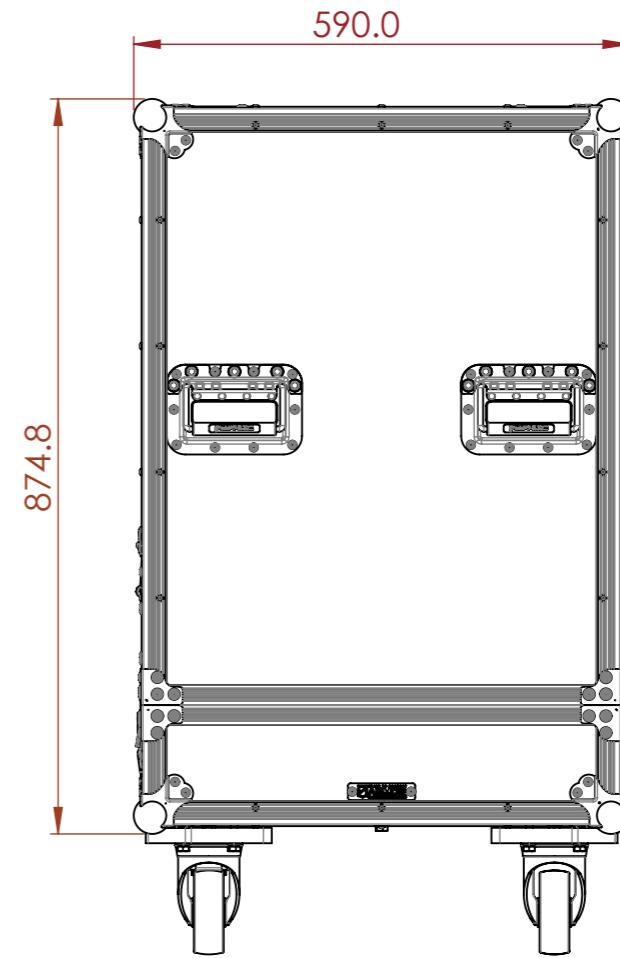
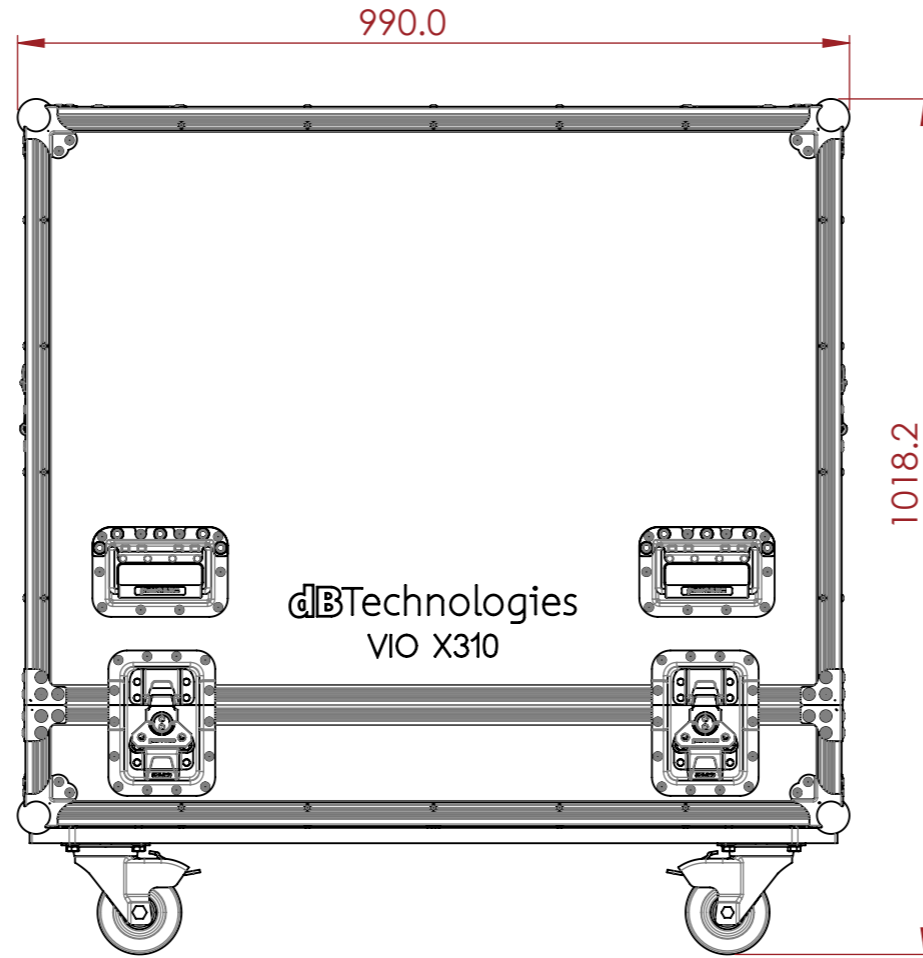

NOTES:  
UNLESS SPECIFIED IN THE DRAWING,  
ALL PRODUCTS DISPLAYED IN THIS  
DRAWING OTHER THAN THE CASE  
ITSELF IS NOT PART OF OUR PRODUCT  
OFFERING.

ESTIMATED WEIGHT (CASE ONLY):

73.0 KG

ITEM CODE:

SPK-DB-X310-VB

DRAWN BY:

HA

CHECKED BY:

AS

SCALE:

NTS



MAIL : [sales@armorcases.com.au](mailto:sales@armorcases.com.au)  
WEB : [www.armorcases.com.au](http://www.armorcases.com.au)