

PRODUCT FEATURES

**CONSTRUCTION**

- 12MM BIRCH VENEER PLYWOOD WITH HPL EXTERIOR FACE AND PVC INTERIOR FACE
- PENN ELCOM LATCHES AND HANDLES

**INSTALLED EQUIPMENT (INCLUDED)**

- NONE

**FEATURES**

- NOT APPLICABLE

**KEY MEASUREMENTS**

- TRUCK FRIENDLY DIMENSIONS

**DESIGN SPECIFICATIONS**

- GENERAL STORAGE SPACE UNDER THE AMP

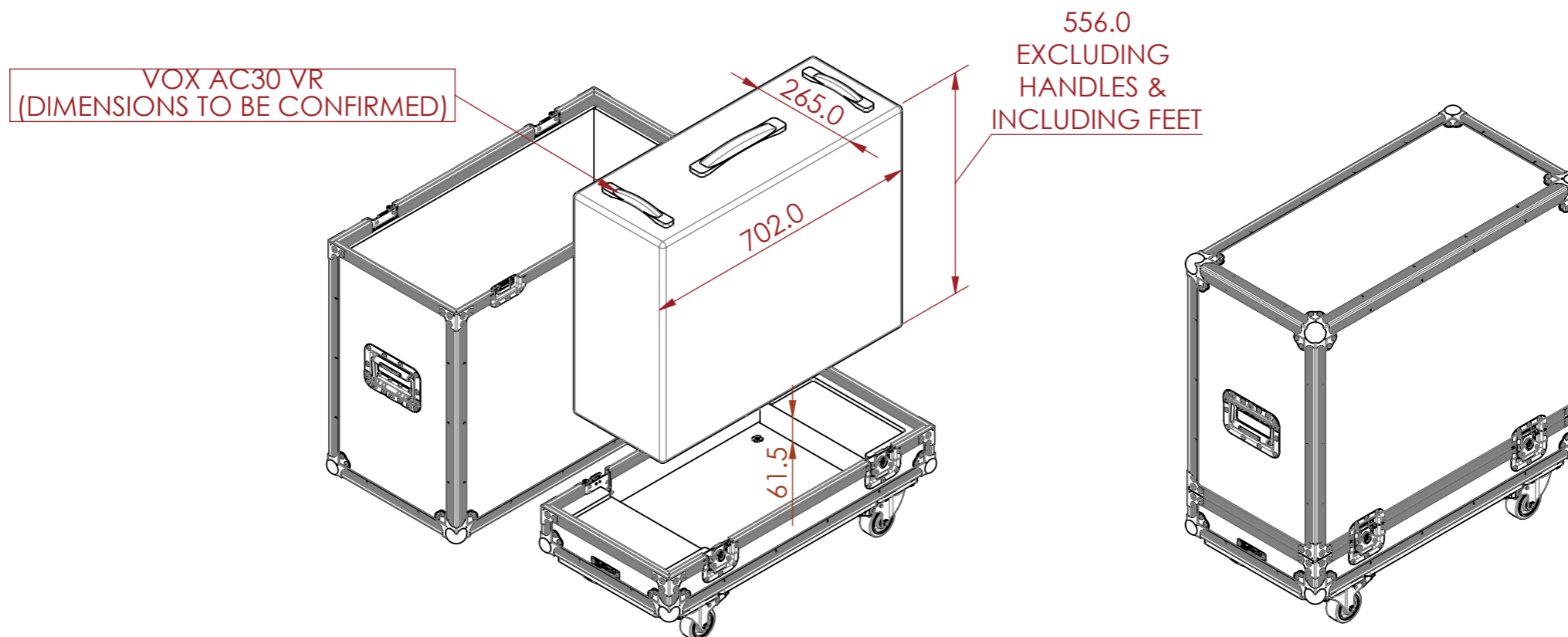
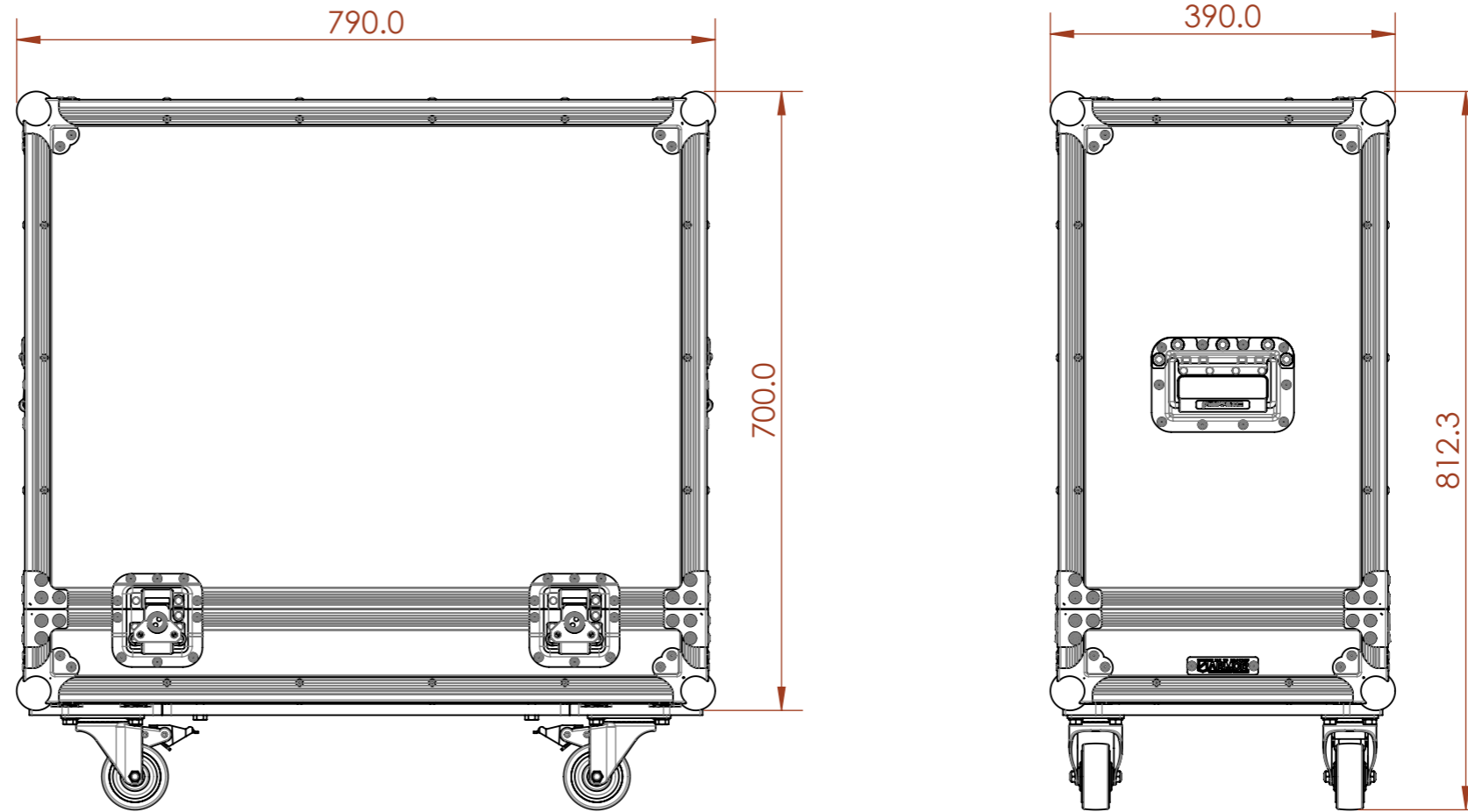

NOTES:  
UNLESS SPECIFIED IN THE DRAWING,  
ALL PRODUCTS DISPLAYED IN THIS  
DRAWING OTHER THAN THE CASE  
ITSELF IS NOT PART OF OUR PRODUCT  
OFFERING.

ESTIMATED WEIGHT (CASE ONLY):  
28.2 KG

ITEM CODE:  
AMP8470-VOX-AC30

DRAWN BY: HA      CHECKED BY: AS

SCALE:  
NTS



MAIL : [sales@armorcases.com.au](mailto:sales@armorcases.com.au)  
WEB : [www.armorcases.com.au](http://www.armorcases.com.au)