

NOTES:
UNLESS SPECIFIED IN THE DRAWING,
ALL PRODUCTS DISPLAYED IN THIS
DRAWING OTHER THAN THE CASE
ITSELF IS NOT PART OF OUR PRODUCT
OFFERING.

PRODUCT FEATURES

CONSTRUCTION

- 9MM BIRCH VENEER PLYWOOD WITH HPL EXTERIOR FACE AND PVC INTERIOR FACE
- PENN ELCOM HARDWARE.

FEATURES

- STORAGE SPACE FOR ANKER BATTERY BANK 767
- EASY TO USE LIFT-OFF-LID DESIGN
- 2X RECESSED HANDLES
- 2X BRAKED CASTORS
- 2X NON BRAKED CASTORS
- 4X CASTOR DISHS FOR EASE OF STACKING

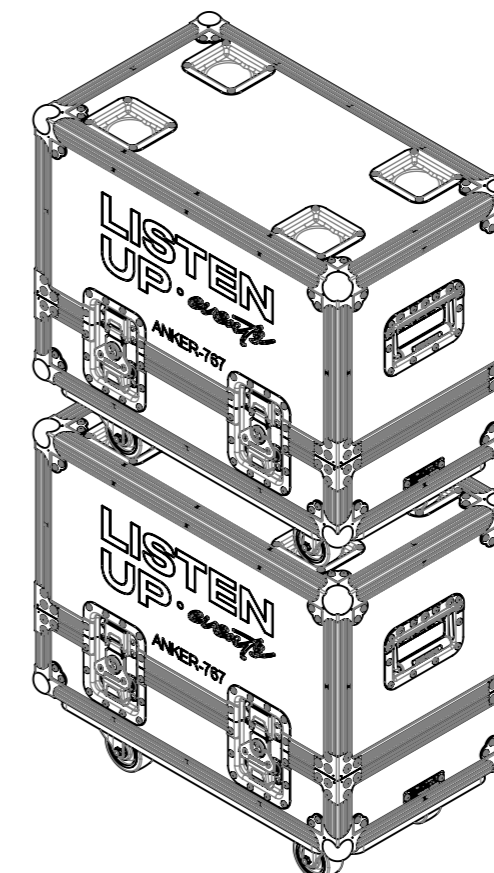
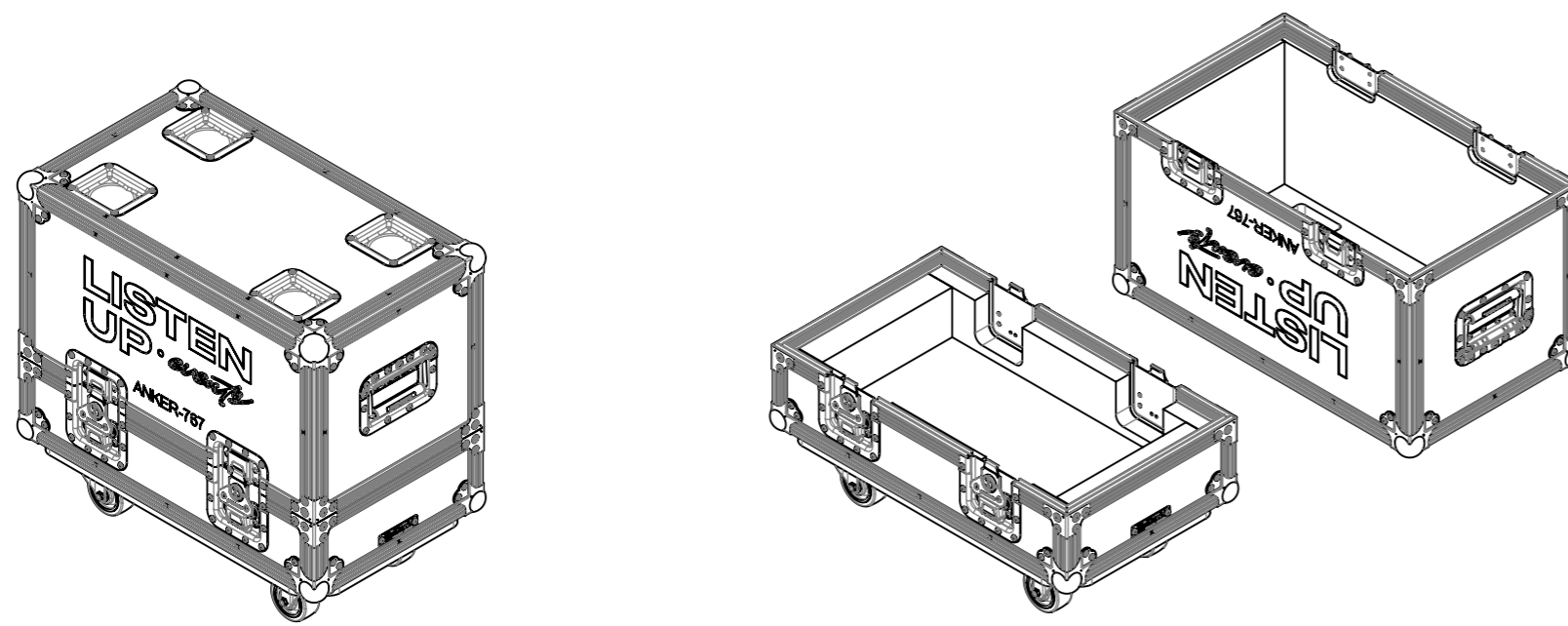

ESTIMATED WEIGHT (CASE ONLY):

20.69 KG

ITEM CODE:

LOL-ANKER-767

DRAWN BY:

K.I

CHECKED BY:

AS

SCALE:

NTS



MAIL : sales@armorcases.com.au
WEB : www.armorcases.com.au