

## PRODUCT FEATURES

### CONSTRUCTION

- 12MM BIRCH VENEER PLYWOOD WITH HPL EXTERIOR FACE AND PVC INTERIOR FACE
- PENN ELCOM HARDWARE

### INSTALLED EQUIPMENT (INCLUDED)

- NONE

### FEATURES

- 2X POCKET STORAGE ON THE FRONT LID FOR STORING CLAMPS AND BRACKETS

### KEY MEASUREMENTS

- NONE

### DESIGN SPECIFICATIONS

- NONE

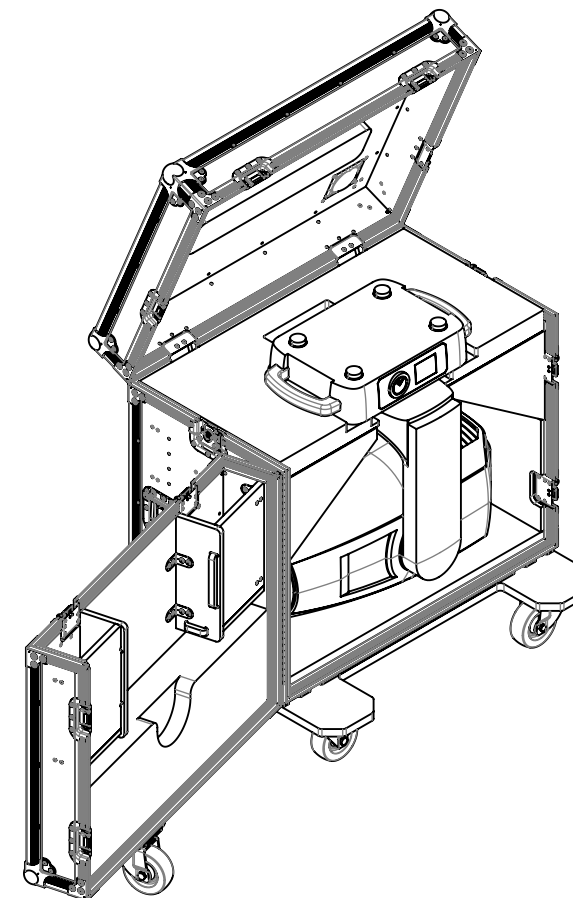
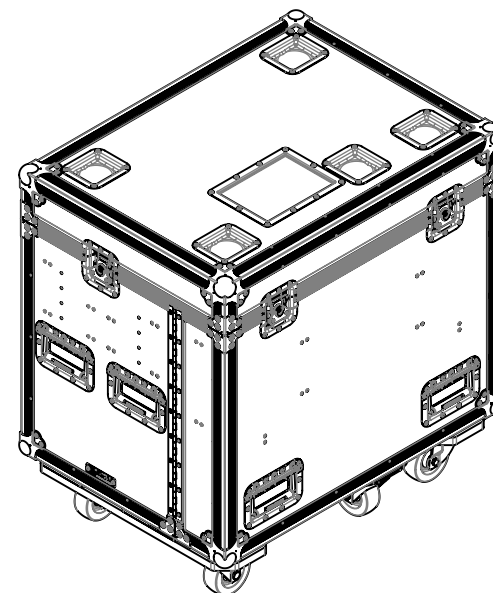
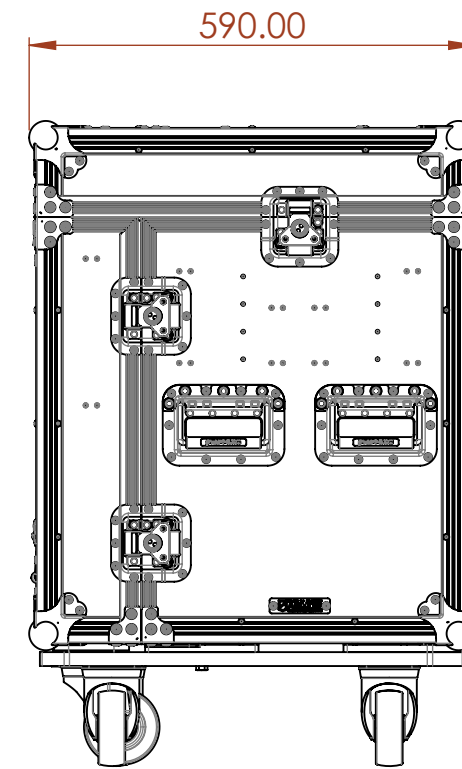
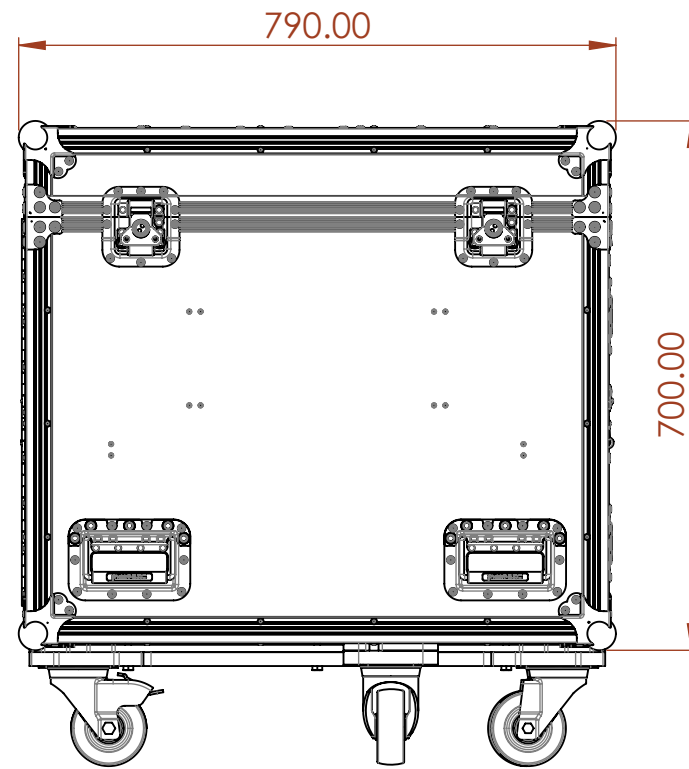

#### NOTES:

UNLESS SPECIFIED IN THE DRAWING, ALL PRODUCTS DISPLAYED IN THIS DRAWING OTHER THAN THE CASE ITSELF IS NOT PART OF OUR PRODUCT OFFERING.

ESTIMATED WEIGHT (CASE ONLY):

55.18 KG

ITEM CODE:

LXMH-AYTN-EURUS

DRAWN BY:

HA

CHECKED BY:

AS

SCALE:

NTS



MAIL : [sales@armorcases.com.au](mailto:sales@armorcases.com.au)  
WEB : [www.armorcases.com.au](http://www.armorcases.com.au)