

PRODUCT FEATURES

CONSTRUCTION

- 9MM BIRCH VENEER PLYWOOD WITH HPL EXTERIOR FACE AND PVC INTERIOR FACE
- PENN ELCOM HARDWARE

FEATURES

- STORAGE SPACE FOR PIONEER CDJ 350 AUDIO MIXER
- EXTRA STORAGE SPACE UNDER PRODUCT FOR STORING ACCESSORIES

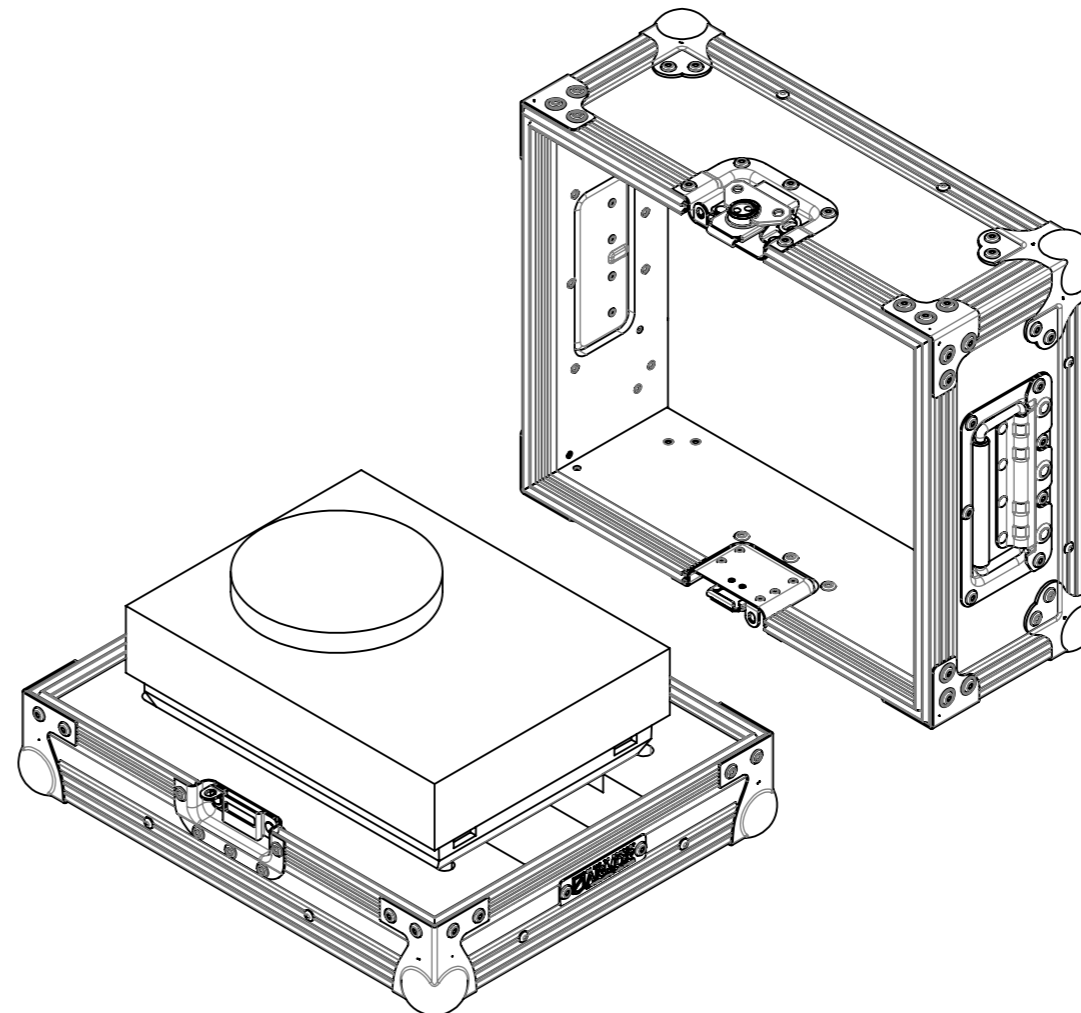
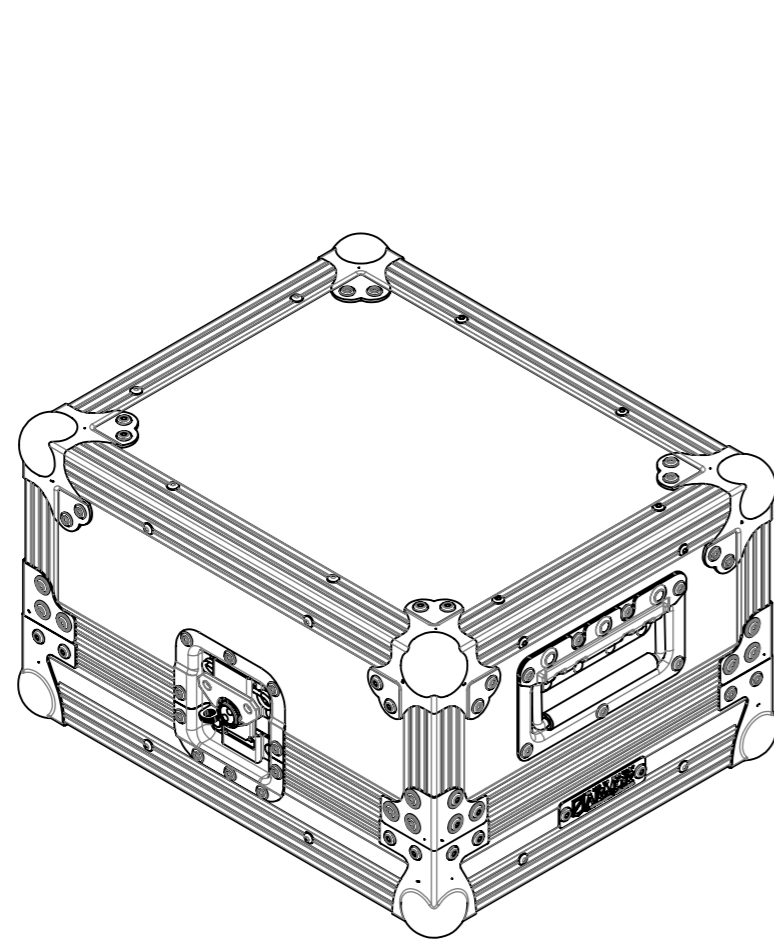
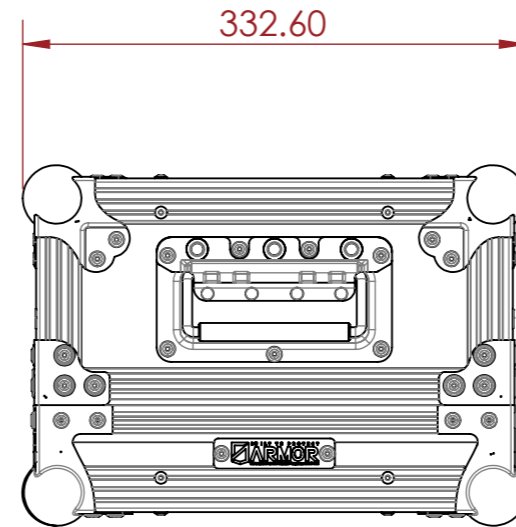
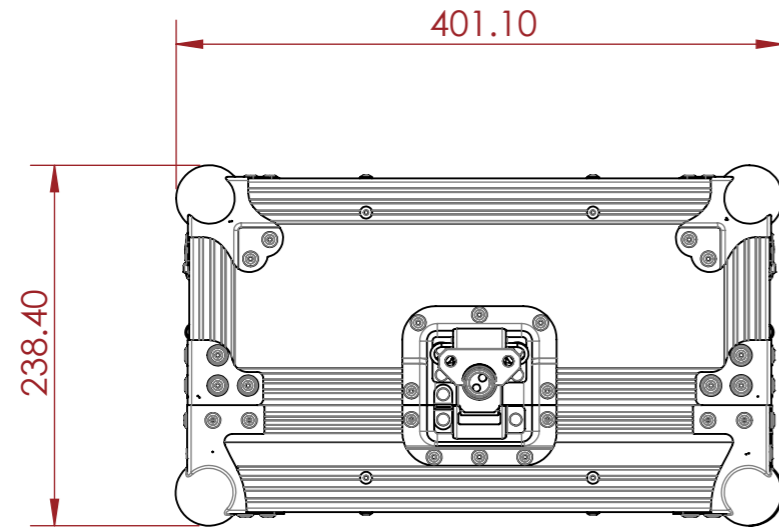

NOTES:
UNLESS SPECIFIED IN THE DRAWING,
ALL PRODUCTS DISPLAYED IN THIS
DRAWING OTHER THAN THE CASE
ITSELF IS NOT PART OF OUR PRODUCT
OFFERING.

ESTIMATED WEIGHT (CASE ONLY):

7.29 KG

ITEM CODE:

MIXR-CDJ-350

DRAWN BY:

K.I

CHECKED BY:

AS

SCALE:

NTS



MAIL : sales@armorcases.com.au
WEB : www.armorcases.com.au