

PRODUCT FEATURES

CONSTRUCTION

- 12MM BIRCH VENEER PLYWOOD WITH HPL EXTERIOR FACE AND PVC INTERIOR FACE
- PENN ELCOM HARDWARE

INSTALLED EQUIPMENT (INCLUDED)

- 2X 2RUS FOR STORING EQUIPMENT

FEATURES

- GAS STRUTS SUPPORTED FOLDABLE ASSEMBLY FOR MIXER
- 2X FOLDABLE VISA MOUNT ARMS FOR MONITORS

KEY MEASUREMENTS

- 1345mm MAXIMUM HEIGHT OF MIXER WHILE IN USE

DESIGN SPECIFICATIONS

- 1X DRAWER FOR GENERAL STORAGE
- 1X POCKET STORAGE ON EACH SIDE OF FLAP DOORS IN THE BASE

NOTES:
UNLESS SPECIFIED IN THE DRAWING,
ALL PRODUCTS DISPLAYED IN THIS
DRAWING OTHER THAN THE CASE
ITSELF IS NOT PART OF OUR PRODUCT
OFFERING.

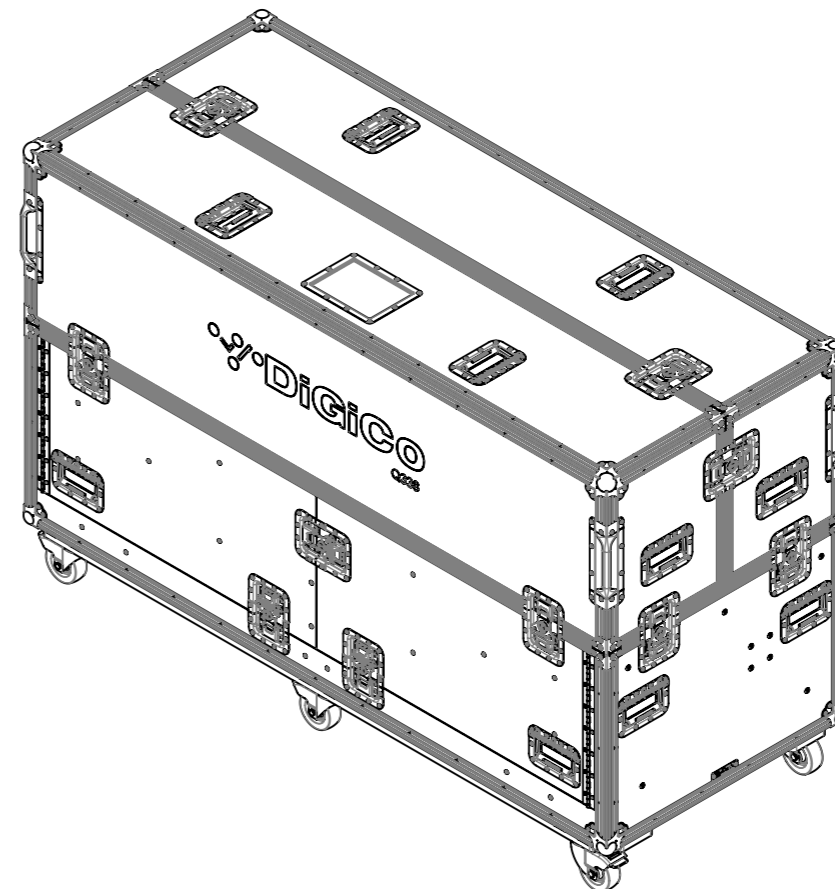
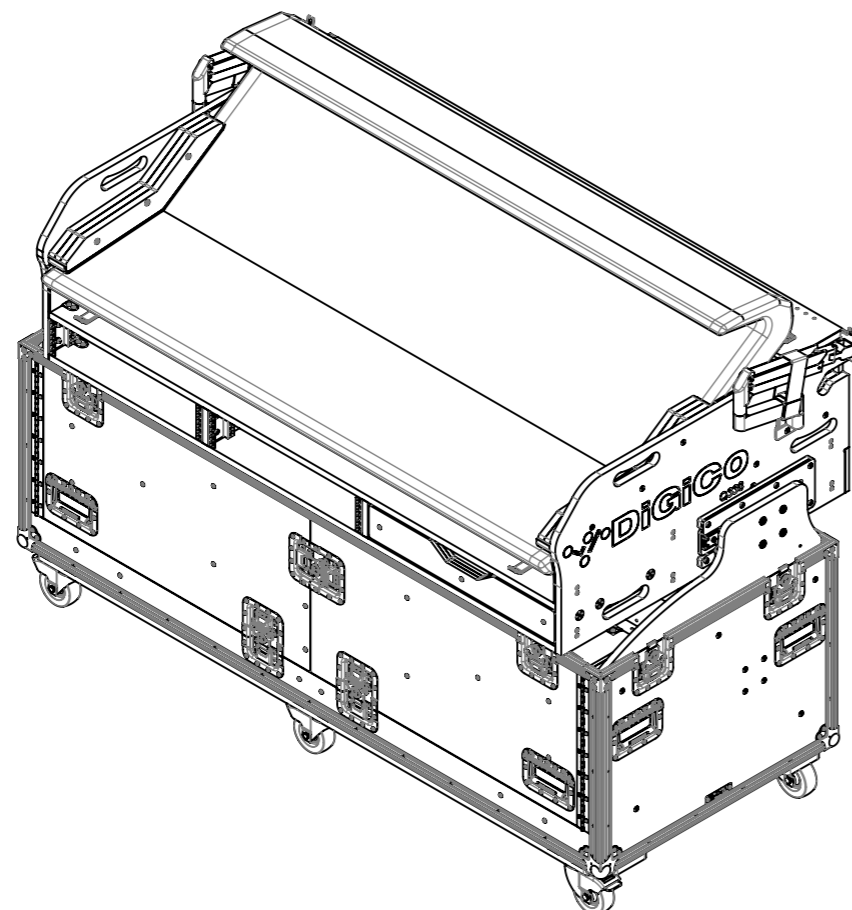
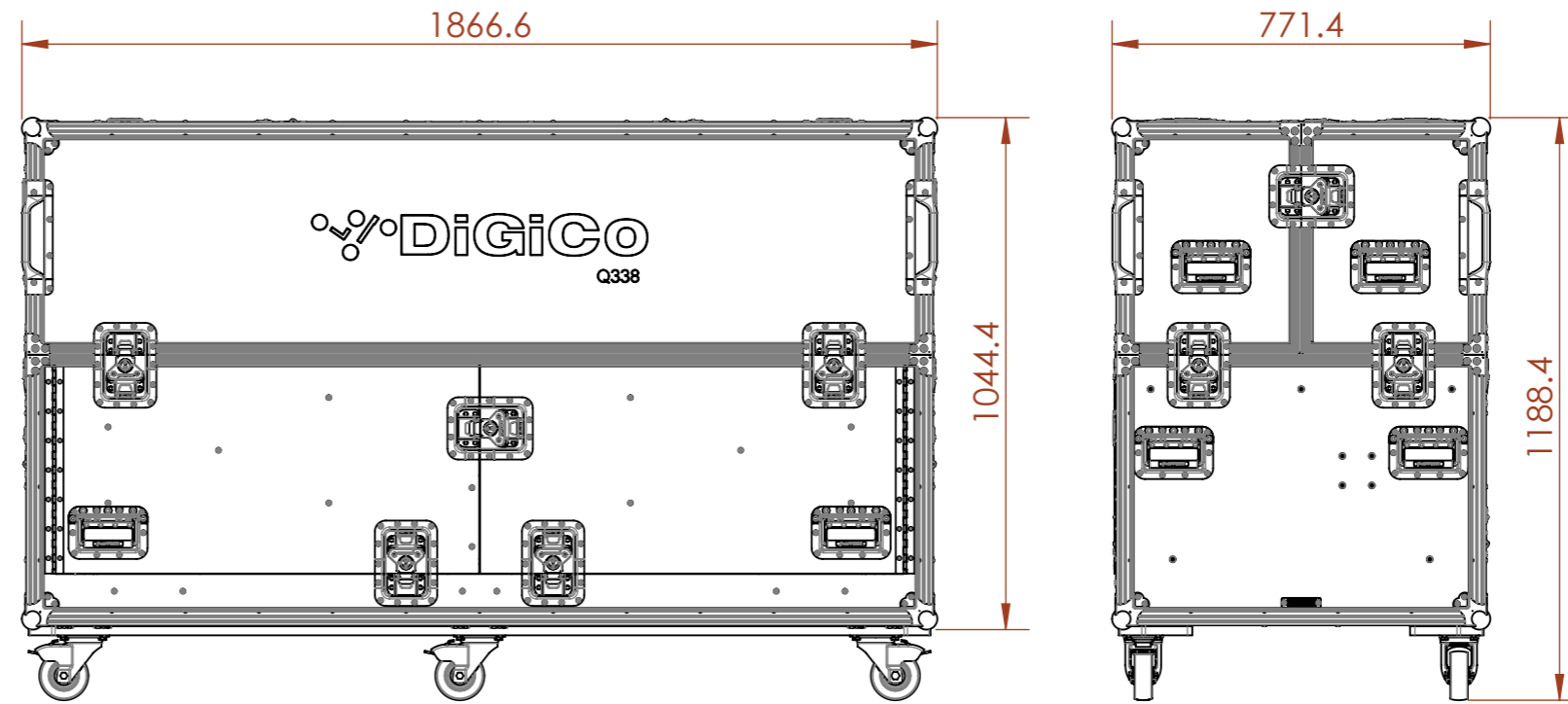

ESTIMATED WEIGHT (CASE ONLY):

218.6 KG

ITEM CODE:

MIXRL-DIGI-Q338

DRAWN BY:

HA

CHECKED BY:

AS

SCALE:

NTS



MAIL : sales@armorcases.com.au
WEB : www.armorcases.com.au