

PRODUCT FEATURES

CONSTRUCTION

- 9MM BIRCH VENEER PLYWOOD WITH HPL EXTERIOR FACE AND PVC INTERIOR FACE
- ARMOR HARDWARE

INSTALLED EQUIPMENT (INCLUDED)

- NONE

FEATURES

- NOT APPLICABLE

KEY MEASUREMENTS

- HEIGHT OF CASE 594MM

DESIGN SPECIFICATIONS

- GENERAL STORAGE SPACE FOR ACCESSORIES
- STORAGE SPACE FOR 3X LENSES

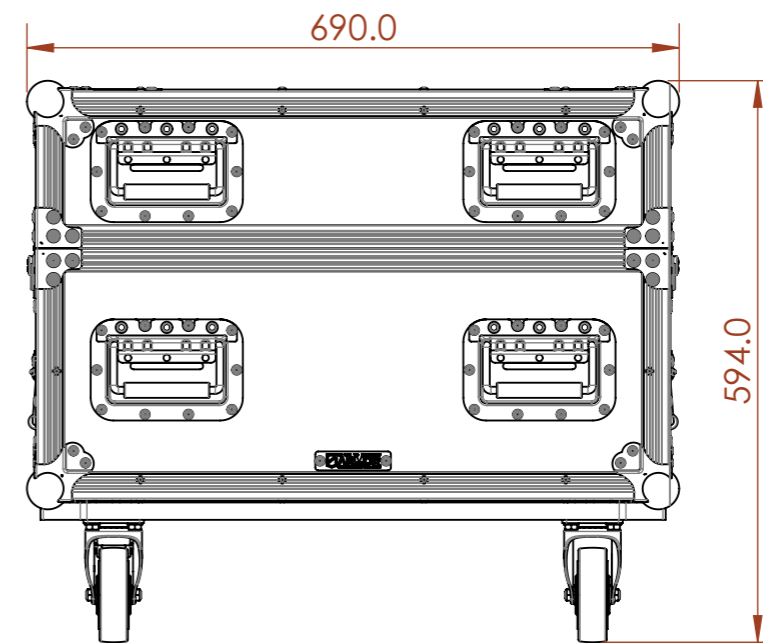
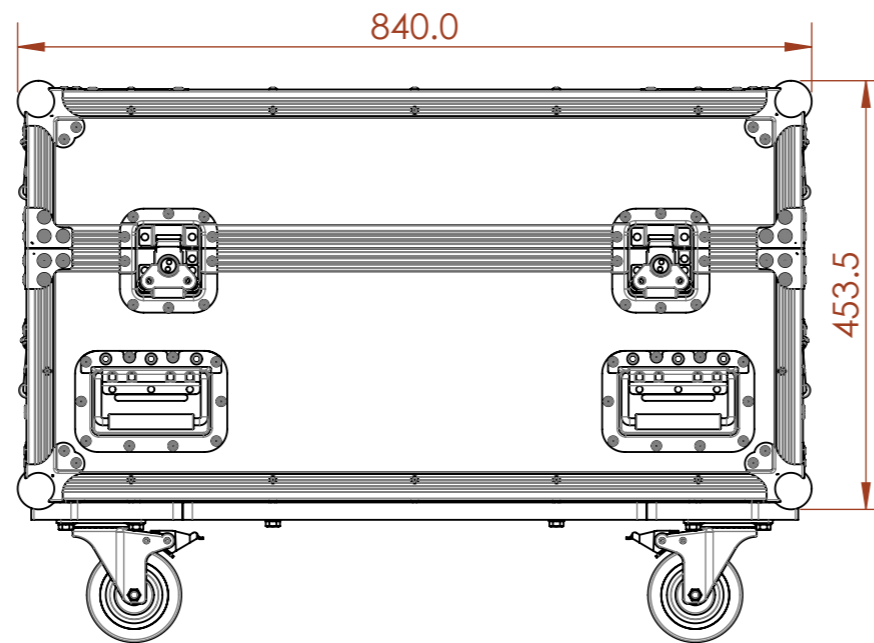

NOTES:
UNLESS SPECIFIED IN THE DRAWING,
ALL PRODUCTS DISPLAYED IN THIS
DRAWING OTHER THAN THE CASE
ITSELF IS NOT PART OF OUR PRODUCT
OFFERING.

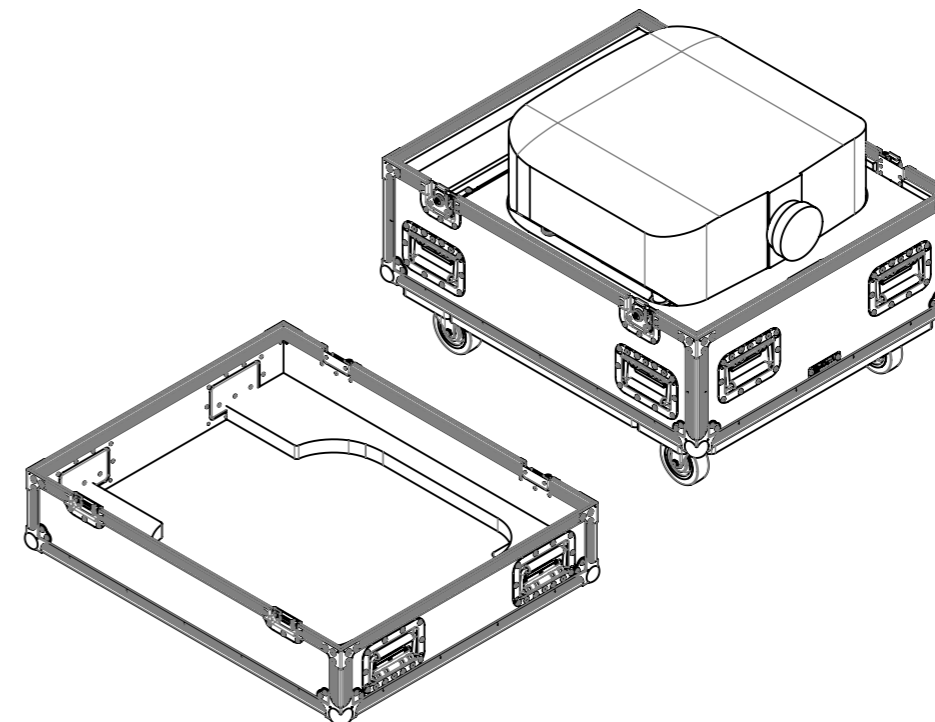
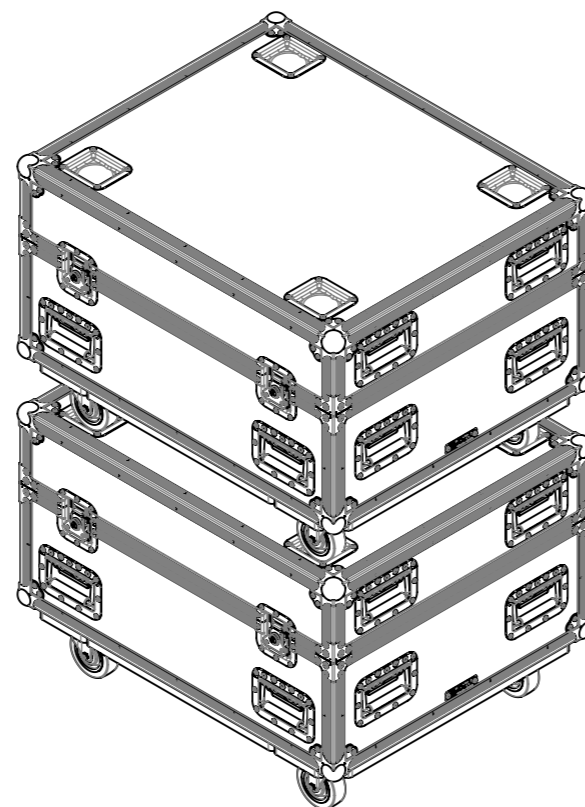
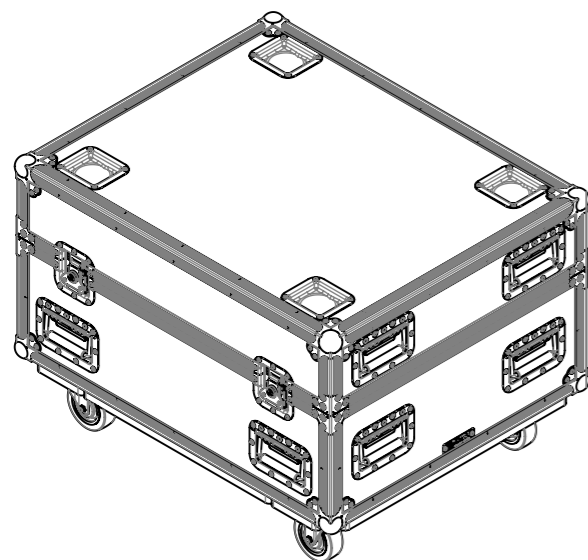

ESTIMATED WEIGHT (CASE ONLY):

47.0 KG

ITEM CODE:

PJTR-EPSN-L1075U

DRAWN BY:

HA

CHECKED BY:

AS

SCALE:

NTS



MAIL : sales@armorcases.com.au
WEB : www.armorcases.com.au