

PRODUCT FEATURES

CONSTRUCTION

- 9MM BIRCH VENEER PLYWOOD WITH HPL EXTERIOR FACE AND PVC INTERIOR FACE
- PENN ELCOM HARDWARE

INSTALLED EQUIPMENT (INCLUDED)

- 3U RACK MOUNT STRIP WITH 600MM DISTANCE FRONT TO BACK

FEATURES

- RECESS HANDLES ON FRONT AND BACK REMOVABLE LIDS
- FEET AND LOCATING DISHES FOR EASE OF STACKING
- LABEL DISH FOR EASE OF RECOGNITION
- OVERLATCH AND KEEPER DISH FOR LOCKING CASES STACKED ON TOP OF EACH OTHER

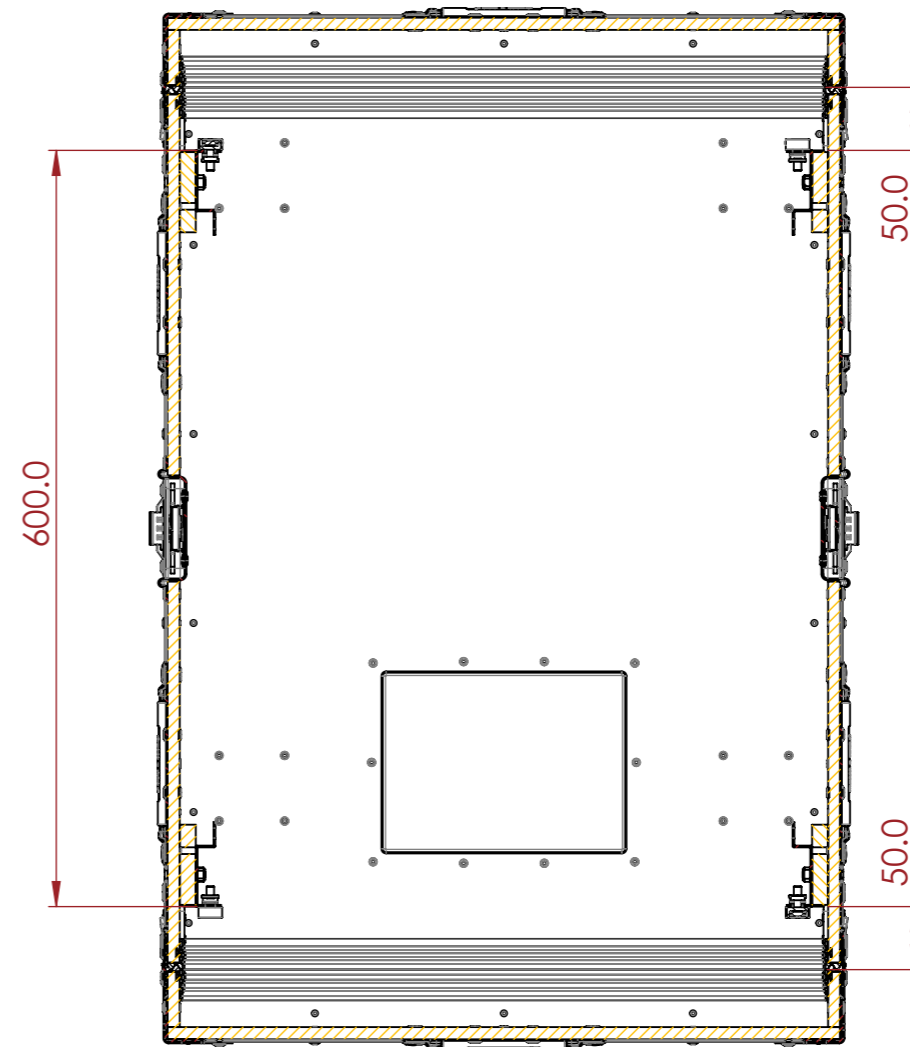
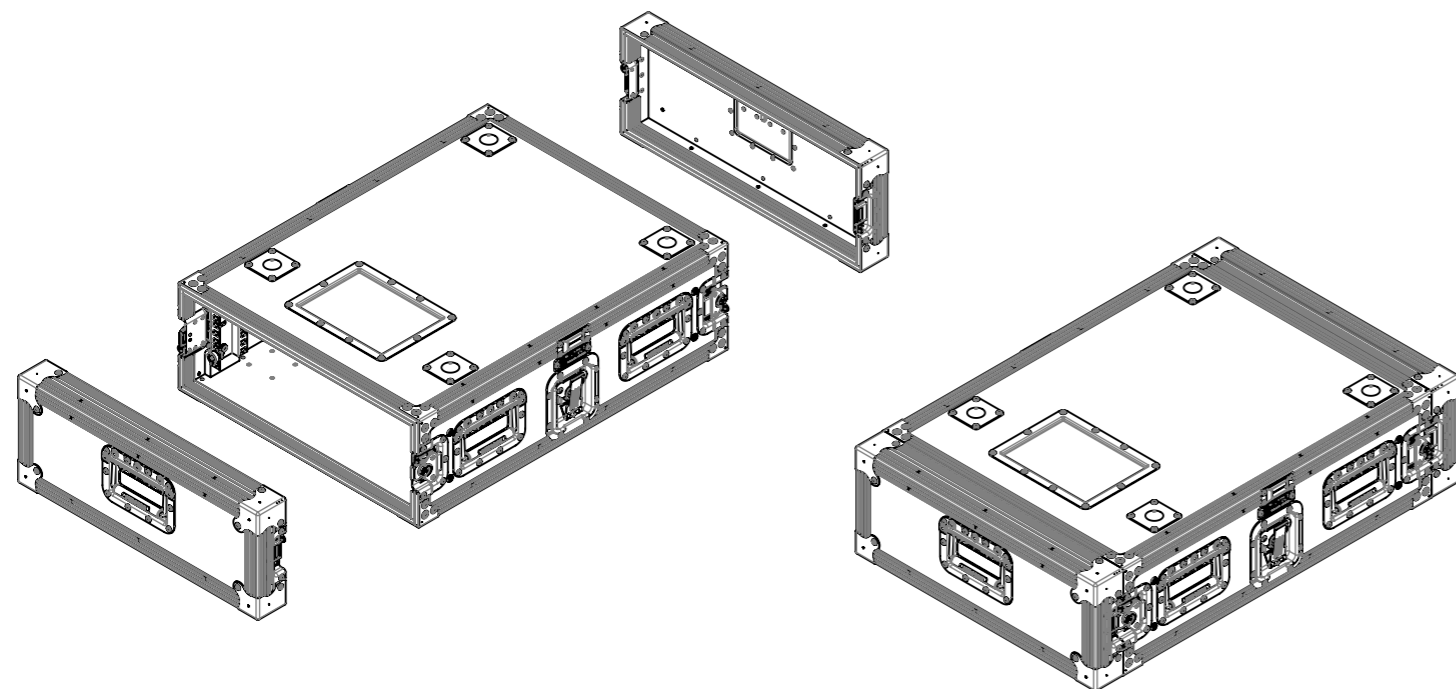

SECTION B-B

NOTES:

UNLESS SPECIFIED IN THE DRAWING, ALL PRODUCTS DISPLAYED IN THIS DRAWING OTHER THAN THE CASE ITSELF IS NOT PART OF OUR PRODUCT OFFERING.

ESTIMATED WEIGHT (CASE ONLY):

17.61 KG

ITEM CODE:

RK-03U-600

DRAWN BY:

K.I

CHECKED BY:

AS

SCALE:

NTS



MAIL : sales@armorcases.com.au
 WEB : www.armorcases.com.au