

PRODUCT FEATURES

CONSTRUCTION

- 9MM BIRCH VENEER PLYWOOD WITH HPL EXTERIOR FACE AND PVC INTERIOR FACE
- PENN ELCOM HARDWARE

FEATURES

- 4X DRAWERS FOR STORING ACCESSORIES
- 1X CORNER HANDLE
- 4X RECESSED HANDLES
- 2X LATCHES
- LABEL DISH FOR EASE OF RECOGNITION
- 2X BRAKED CASTORS (RUBBER)
- 3X NON BRAKED CASTORS (RUBBER)

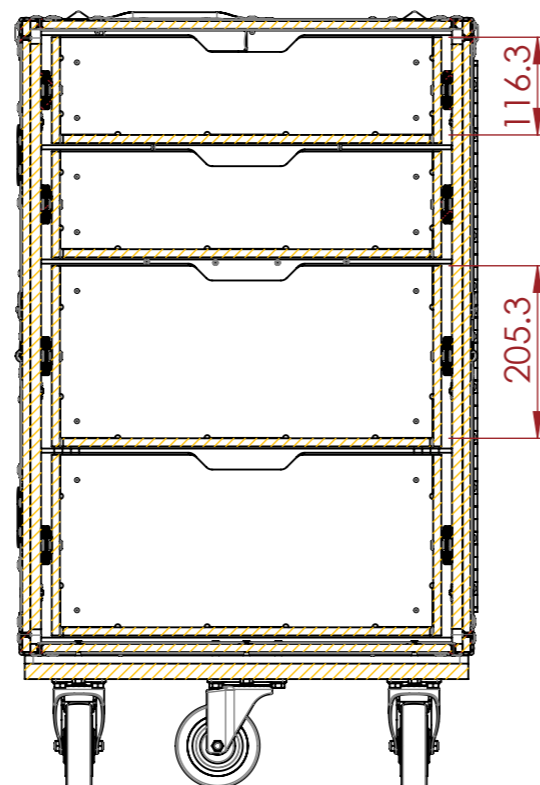
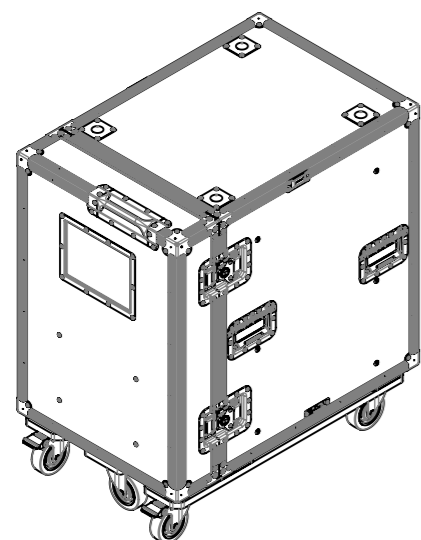
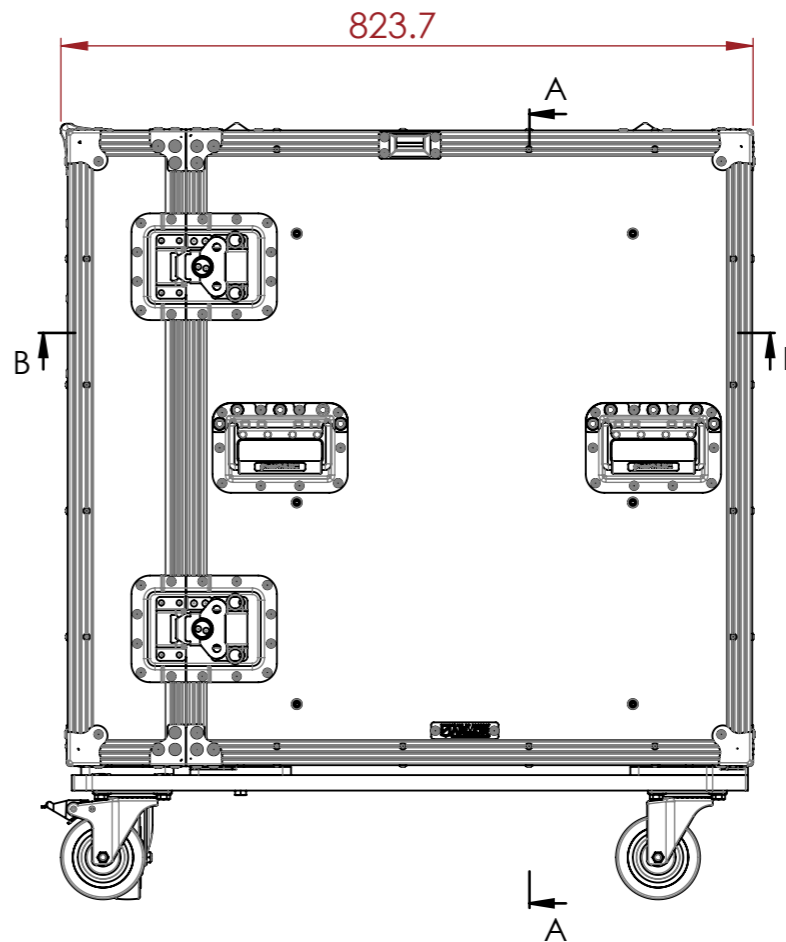
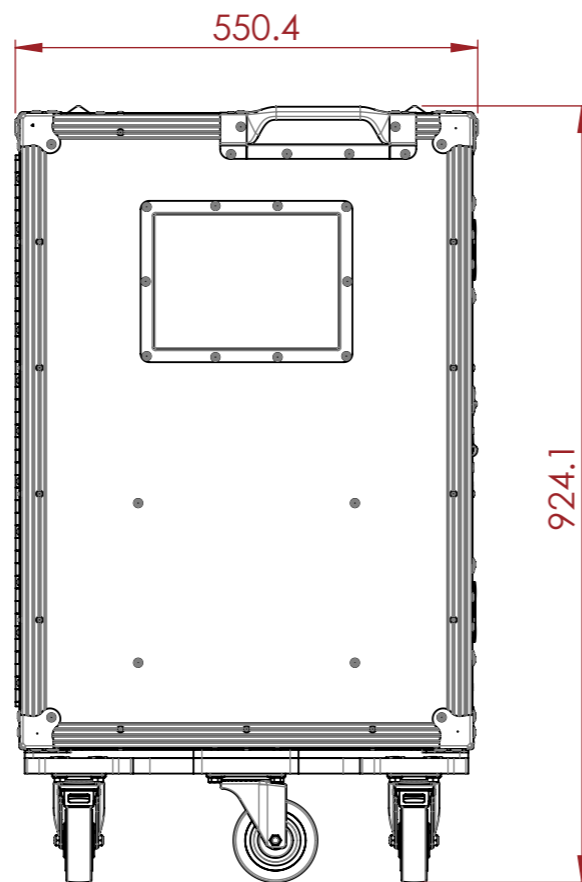

SECTION A-A

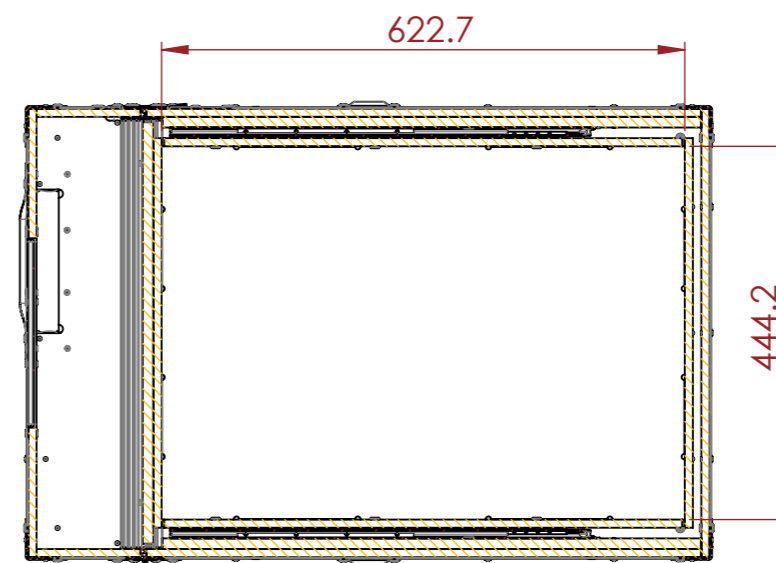

SECTION B-B

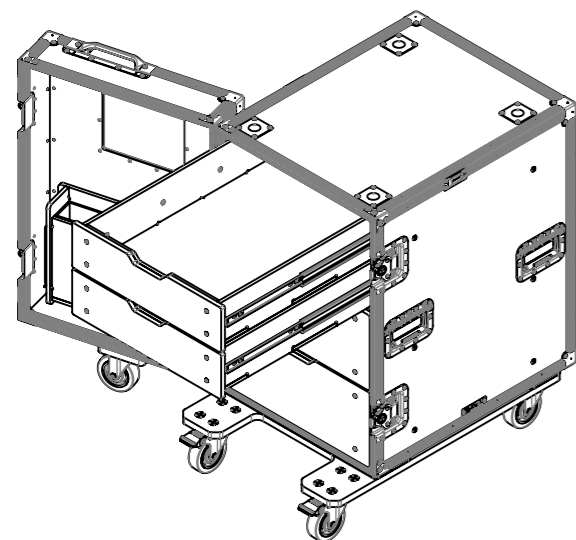

NOTES:
UNLESS SPECIFIED IN THE DRAWING,
ALL PRODUCTS DISPLAYED IN THIS
DRAWING OTHER THAN THE CASE
ITSELF IS NOT PART OF OUR PRODUCT
OFFERING.

ESTIMATED WEIGHT (CASE ONLY):

74.1 KG

ITEM CODE:

UTL-DR16U-OA

DRAWN BY:

K.I

CHECKED BY:

AS

SCALE:

NTS



MAIL : sales@armorcases.com.au
WEB : www.armorcases.com.au