

PRODUCT FEATURES

CONSTRUCTION

- 12MM BIRCH VENEER PLYWOOD WITH HPL EXTERIOR FACE AND PVC INTERIOR FACE
- PENN ELCOM HARDWARE

INSTALLED EQUIPMENT (NOT INCLUDED)

- ALLEN & HEATH DLIVE S5000

INSTALLED EQUIPMENT (INCLUDED)

- 2X FOLDABLE MONITOR ARM

FEATURES

- GAS STRUTS SUPPORTED CONSOLE DECK
- 2X DOOR POCKETS

KEY MEASUREMENTS

DOOR POCKET INTERNAL-520.6X116.6X308.3(WXDWH)

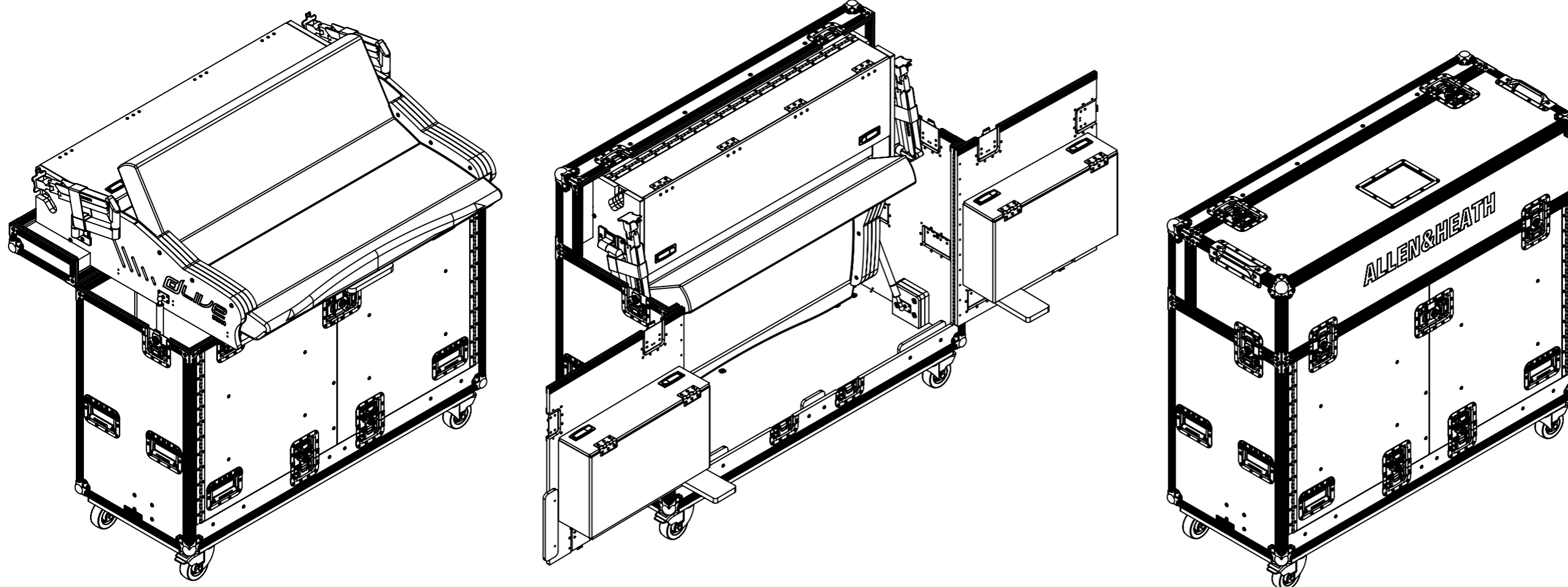
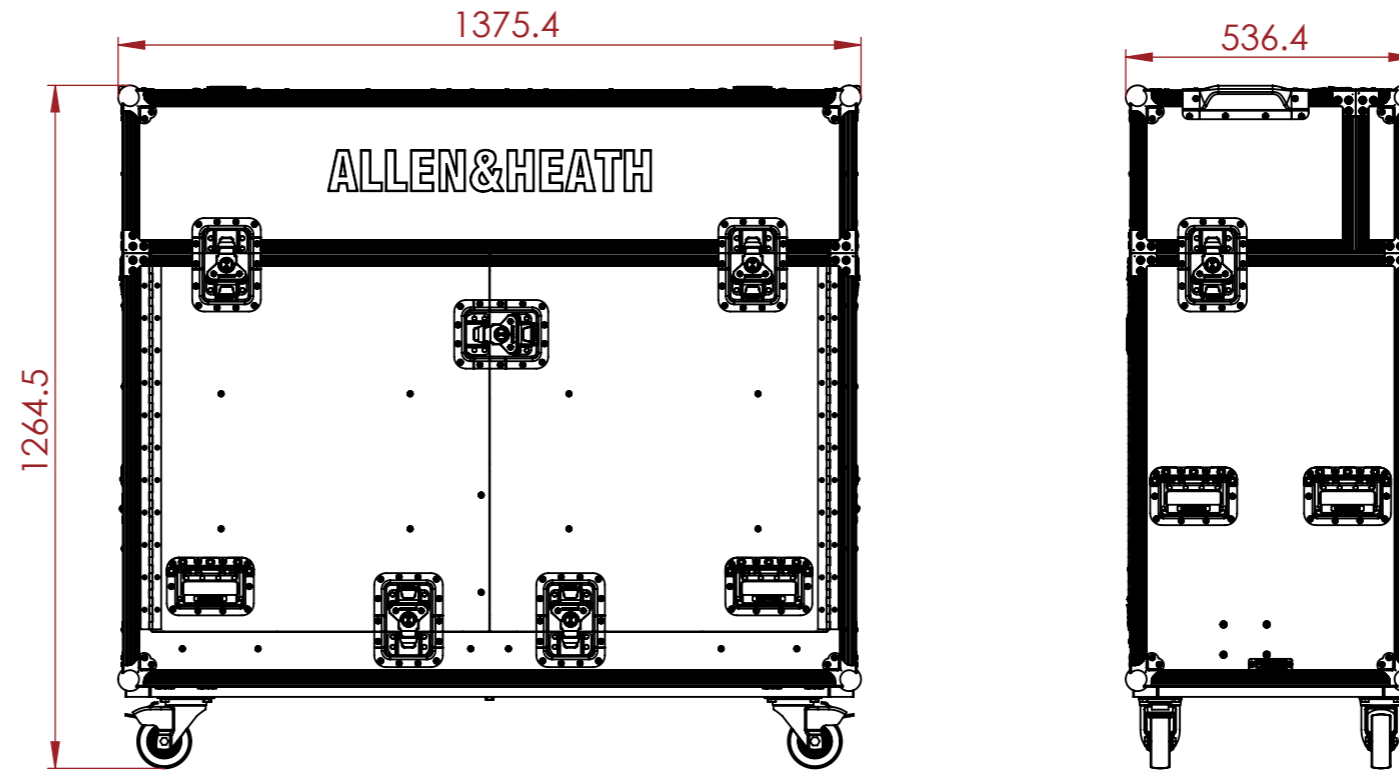

NOTES:

UNLESS SPECIFIED IN THE DRAWING, ALL PRODUCTS DISPLAYED IN THIS DRAWING OTHER THAN THE CASE ITSELF IS NOT PART OF OUR PRODUCT OFFERING.

ESTIMATED WEIGHT (CASE ONLY):

119.7 KG

ITEM CODE:

MIXR-AH-S5000-L

DRAWN BY:

RP

CHECKED BY:

AS

SCALE:

NTS



MAIL : sales@armorcases.com.au
WEB : www.armorcases.com.au